

LUXYCLAD[®] Aluminum
Architectural
Systems

INSTALLATION MANUAL



76 RIDLEY ROAD
ST CATHARINES ON L2S 3Y8

www.luxyclad.com
1 877 255 1022

Installation Information Page 2 - 3

Before you start
Storage
Site Preparation
Installation Tips

Care and Maintenance..... Page 4

Frequency Recommendation
Touch-Up
Coastal Environments Warning
What to Avoid List
Summer Maintenance Tip

Safety Information..... Page 5

Surface Temperature & Sun Exposure
Personal Protective Equipment (PPE)
Cutting & Fabrication Safety
Handling & Safety Guidelines
General Safety
Emergency Procedures

Tools Page 6

Tools and Hardware for LUXYCLAD® Installation
Cutting Tips

Expansion & Contraction..... Page 7

Material Behavior
Common Mistakes to Avoid
Design and Installation Tips
Industry Standards and Guidelines

Profile Minimum Bend Radius Table Page 8

Understanding the Bending Radius Estimate
What is the Minimum Bend Radius?
Why Use 10-20 Times the Profile Thickness?
Summary

Components..... Page 9

Horizontal Siding Installation..... Page 10 - 22

| | |
|---------------------------------|--|
| Starter Strip & V-Groove Siding | 1" Precision Strater Strip & V-Groove Siding |
| Outside Corner | 1" Precision Finishing Cap + Base |
| Inside Corner | 1" Precision J-Trim Base + Cap |
| Flat Cap | 1" Precision J-Trim |
| J-Trim | 1" Precision Outside Corner + Base |
| Finishing Cap | |

Horizontal Siding Installation..... Page 23 - 25

Wall at window with Ext. Insul'n + Horizontal Siding Plan View
Wall at window Horizontal Siding Plan View

Vertical Siding Installation..... Page 26 - 27

Wall at Corner with Ext. Insul'n + Vertical Siding Plan View

Soffit Installation..... Page 28 - 30

Wall at Soffit with Ext. Insul'n + Gable Roof Section View
Wall at Soffit Flat Roof Section View

Dear customer, congratulations on your purchase of this LUXYCLAD® product! Known for its outstanding qualities, LUXYCLAD® is a rear ventilated rain screen cladding system that is increasingly becoming the siding choice for homeowners, contractors, architects, and builders. Compared to other siding products, LUXYCLAD® is attractive, durable, easy to maintain, fire-resistant, recyclable, LEED compliant, impervious to insects, and does not bend, warp, rot or peel.

LUXYCLAD® is available in a variety of finishes, ranging from solid and metallic colours, to rich wood grain surfaces that simulate the look of real wood.

Please read the installation guidelines completely. The installation techniques in this manual describe and illustrate the steps involved in installing LUXYCLAD® siding, soffit, and trim. Their purpose is to provide detailed information and how-to tips that will simplify the installation processes.

LUXYCLAD® will not accept any liability or responsibility under its written warranty for product failure caused by application that does not meet the requirements for proper installation. These requirements are outlined throughout this document. Before you begin any siding project, you need to be aware of building code requirements in the geographic areas where you are working, and how the code relates to both the instructions given in this manual and by the siding manufacturer.

You must always observe the requirements of local building codes, as they represent the legal requirements for an installation in a given jurisdiction. However, most local codes are based on the national building code model. Model codes themselves do not have the force of law until they are adopted by a state or local jurisdiction. In the United States, the primary source of model codes is the International Code Council (www.iccsafe.org), which publishes the International Building Code (IBC) and International Residential Code (IRC).

In Canada, the primary model code is the National Building Code (NBC), published by the National Research Council of Canada (www.nrc-cnrc.gc.ca).

No instruction manual can anticipate all the questions or conditions that might arise during installation.

Recognizing this, we've focused on the tools and techniques used to complete typical installations.

If you encounter an installation situation not covered in this manual, we suggest you contact the LUXYCLAD® Sales Support Group at 1-877-255-1022.

The manufacturer has provided these suggested instructions as installation guidelines. The manufacturer, however, neither installs the panels nor has any control over the installation. It is the responsibility of the contractor and/or the installer to ensure panels are installed in accordance with these instructions and any applicable building codes. The manufacturer assumes no liability for either improper installation or personal injury resulting from improper use or installation.

These instructions are prepared for persons experienced in the field of soffit and siding installation and assume a foundation of working knowledge regarding the required tools and application process. LUXYCLAD® is a rear ventilated rain screen cladding system which meets the requirements of Part 9 of the Building Code, when installed according to these instructions.

In most applications, LUXYCLAD® does not require traditional rain screen furring, please refer to your local building code to verify the air gap required. However, additional horizontal furring is recommended for vertical installations.

LUXYCLAD® is very similar to vinyl siding and soffit installation with the exception of the cutting and flexibility. LUXYCLAD® requires more precision and time to install. **It is highly recommended that LUXYCLAD® be installed by an experienced professional.**

Before you start

→ Before installing any material, inspect it for breakage, foreign objects, surface defects, correct product, correct colour, and colour consistency. In addition, check for any wet or saturated product.

Do NOT install any questionable product!

If you find a siding defect, contact LUXYCLAD®'s Consumer Service Group immediately at: 1-877-255-1022.

If you elect to install questionable product and a manufacturing defect is not found to be the source of the problem, any claim may not be honoured.

Before you begin to work with LUXYCLAD® siding, it is important that you and the members of your crew have read and understood the information in this guide. Also, be sure to possess the right tools, fasteners, and accessories before you begin.

OSHA (Occupational Safety and Health Administration) requires workers to always use the appropriate PPE (Personal Protection Equipment). More information about personal protective equipment is available at:

www.osha.gov/SLTC/personalprotectiveequipment

Consult the Material Safety Data Sheet (MSDS) on our website, www.luxyclad.com, and a qualified industrial hygienist for further health and safety information related to this product.

An important note about LUXYCLAD® warranties:

Failure to comply with LUXYCLAD® installation instructions and/or applicable building codes may affect product performance and void the product warranty.

It is highly recommended to use a trained LUXYCLAD® independent installer, if available, or an installer who has previous experience installing similar premium siding and soffit systems.

Storage

→ Store the cartons on a flat surface that supports the entire carton length.

Do not store LUXYCLAD® siding or trim directly on the ground.

If a covered area such as a garage is not available on the job site, place pallets on wood blocks to allow air flow underneath the pallet. Keep the cartons dry.

If palletized LUXYCLAD® is to be placed on a damp surface, place a vapour barrier on ground underneath the pallet. Cover with plastic tarp or similar bonnet to keep the product dry and prevent moisture from settling. Store the cartons away from areas where falling objects or other construction activity may occur or cause damage.

Do not store the cartons in stacks that are more than 6 boxes high.

Site Preparation

→ Prior to installation, verify that the substrate is clean, dry, level, and structurally sound. Inspect the surface for any damage, irregularities, or debris that could affect the installation or the performance of the system. Address any issues identified to ensure a proper and secure attachment of the panels.

Installation Tips

→ LUXYCLAD® soffit and siding is a tongue and groove installation. The ability to shim or spread each board by up to 1/16" allows you to compensate for framing discrepancies.

→ When mitering corners or creating butt joints, it is recommended to use touch-up pens to trace over the exposed cut during the install, in order to eliminate the possibility of metal glint. However, to reduce the look of glint entirely, it is recommended to use a finished end; in this scenario a touch-up pen is not required.

Care and Maintenance

→ The beauty of LUXYCLAD® is maintained with little effort. Although anything outdoor is likely to collect dirt, a heavy rain will often wash this dirt away and maintain the look of a clean LUXYCLAD® siding system.

It is also possible to wash our product using a garden hose. Do not use a pressure washer. If rain or hosing does not do a satisfactory job, follow these simple instructions:

1. Use an ordinary, long-handled car washing brush. This brush has soft bristles with handles to fasten onto the end of a hose, allowing the siding to be washed similarly to a car. Avoid using stiff bristle brushes or abrasive cleaners that may change the gloss of the cleaned area and/or cause the siding to appear splotchy.

2. When washing down an entire house or building, start at the bottom and work up to the top in order to prevent streaking. Rinse cleaning solution with water before it dries on the material.

If your house or building consists of any brick or stone cladding, cover this material to ensure it is not affected by any run-off.

3. Follow the precautionary labeling instructions on the cleaning agent container. Protect shrubs and other foliage from direct contact with cleaning agents.

4. To remove soot and grime found in industrial areas, wipe down the siding with a mild detergent (PH-6-7) made up of the following:

- 1/3 cup powdered detergent (e.g. Fab, Tide, or equivalent powder detergent)*
- 2/3 cup powdered household cleaner (e.g., Soilax, Spic & Span, or equivalent)*

- 1 gallon of water

Frequency Recommendation

→ Recommend a simple water rinse once a year (typically in the Spring) to remove winter salt, pollen, and dust.

Touch-Up

→ Accidental Scratches? If your siding is scratched during landscaping or activity, contact us for a LUXYCLAD® Color-Match Touch-Up Pen to seal the finish and maintain the aesthetic.

Coastal Environments Warning

→ If your project is located within 3 miles (5km) of the ocean, we recommend rinsing the siding every 3-6 months to prevent salt-air buildup.

What to Avoid List

- No Steel Wool or Scouring Pads.
- No Acid-based cleaners.
- No Abrasive "Magic Eraser" style sponges (these will ruin the gloss level).

Summer Maintenance Tip

→ Avoid Cleaning in Direct Sun: For the best streak-free results, try to wash the siding on a cloudy day or when the surface is in the shade. If the metal is hot to the touch, the cleaning solution may dry too fast and leave water spots.

Surface Temperature & Sun Exposure

→ LUXYCLAD® boards are manufactured from high-quality architectural aluminum. When exposed to direct sunlight, especially during hot weather, the surface of the boards can reach high temperatures and may cause burns if touched.

- Do not leave Luxyclad boards lying flat in direct sunlight for extended periods prior to installation.
- If boards must be stored outdoors, ensure they are covered, shaded, or stacked in a way that minimizes sun exposure.
- Use caution when handling boards that have been exposed to the sun. Always check the surface temperature before touching, and use protective gloves if necessary.
- Warn all workers and installers of the potential burn hazard from sun-heated aluminum surfaces.
- Failure to follow these guidelines may result in injury.

Personal Protective Equipment (PPE)

→ Proper PPE is essential for handling, cutting, and installing LUXYCLAD® products. Workers should always wear heavy-duty gloves to protect against sharp edges and hot surfaces, long sleeves and pants to reduce skin exposure, and safety glasses or goggles to guard against flying debris during cutting or drilling.

When performing tasks that generate dust or fumes, such as cutting or sanding, use a suitable respirator or dust mask rated for aluminum particulates. Hearing protection should be worn when using power tools. Refer to OSHA guidelines for comprehensive PPE requirements and ensure all PPE is in good condition and fitted correctly.

See: www.osha.gov/SLTC/personalprotectiveequipment

Cutting & Fabrication Safety

→ When cutting or fabricating LUXYCLAD® boards, use only tools recommended by the manufacturer, such as fine-toothed saws or metal shears, to minimize rough edges and airborne particulates. Wear a dust mask or respirator, safety glasses, and gloves at all times. Clean up metal shavings and dust immediately after cutting to prevent slips, falls, or contamination of the work area. Dispose of all debris according to local regulations.

Handling & Safety Guidelines

→ LUXYCLAD® boards can be long, heavy, and awkward to move. To prevent personal injury and avoid damaging the prefinished surface, please follow these handling procedures:

- Team Lifting: It is highly recommended that siding and accessories be carried by two or more people to distribute weight evenly and prevent overexertion.
- Vertical Carrying: To maintain the structural integrity of the boards and avoid bowing, all panels must be carried in a vertical position.
- Proper Lifting Technique: Always keep your back straight, lift with your legs, and avoid twisting your body. For exceptionally heavy loads, use mechanical equipment such as carts or forklifts.
- Scratch Prevention: Do not slide boards against one another when removing them from the pallet, as this will scratch the prefinished surface below. Always lift the board directly upward.
- Site Preparation: Plan your route before moving materials to ensure it is free of tripping hazards. Always store boards on a stable, level surface to prevent accidental movement or warping.





General Safety

→ Maintain a clean, organized, and well-lit work area at all times to reduce the risk of accidents. Ensure all workers are familiar with Luxyclad's safety guidelines and have received proper safety training relevant to their tasks. Supervisors should conduct regular safety meetings and inspections to reinforce safe practices and identify potential hazards. Encourage prompt reporting of any injuries, near-misses, or unsafe conditions to the site supervisor so corrective action can be taken immediately.

Emergency Procedures

→ All workers should be aware of the location of first aid kits, fire extinguishers, and emergency exits. In the event of burns, cuts, or other injuries, seek medical attention promptly and follow established site emergency protocols. Report serious incidents to the appropriate authorities as required. Keep emergency contact information posted in a visible location and review emergency procedures with all team members at project start.

Tools and Hardware for LUXYCLAD® Installation

| | |
|---|--|
|  | <p>To cut LUXYCLAD® use a compound Mitre saw and a small table saw, with a blade for non-ferrous materials.</p> |
|  | <p>Dewalt DW 3229-12" 80T non-ferrous metal cutting blade Holes for pot lights up to 4" - use appropriate hole saws.</p> <p>Note: Larger holes will require a jigsaw. Protect surface prior to cutting holes.</p> |
|  | <p>LUXYCLAD® is fastened using the aluminum rainscreen clips provided with the product order. These clips create the rear ventilation plane (air gap) and allow for movement cause by thermal expansion and contraction.</p> <p>Use a 1-1/2" length, #8 screw with corrosion resistance suitable for the application and climate. This will allow the product to be removed, if required, without damage. Screws also allow the installer to "back off" the screw and shim to address substrate discrepancies. This system allows for rain screen clips to be fastened every 32" O/C (on center). For high wind areas, it is recommended to increase the fastening spacing to 16" O/C (on center).</p> |
|  | <p>Common hand tools, such as squares, chalk lines, levels, and tape measures are needed for proper installation.</p> |

Cutting Tips

→ LUXYCLAD® is a finished material, complete upon installation. To ensure a high-quality, long-lasting result, careful handling during cutting is essential. The following tips will help you achieve a professional finish:

1. Use the Right Tools:

Utilize a compound miter saw and a small table saw equipped with blades designed for non-ferrous materials. This ensures clean cuts and minimizes damage to the surface.

2. Protect the Finish:

Tape the face of the trim saw surface and the table saw surface before cutting to prevent marring and scratches. Taping helps maintain the appearance of the finish and reduces the need for touch-up.

3. Cutting Orientation:

Cut face up whenever possible. Cutting face up provides a cleaner edge and reduces the risk of damaging the visible surface.

4. Touch-Up After Cutting:

Use touch-up pens (available in light and dark shades) to cover exposed aluminum ends and scratches. This maintains the aesthetic quality of the finished product.

5. General Care:

Handle with care during installation to avoid dents or scratches. Properly protected and cut panels will result in a premium, maintenance-free appearance for years to come.

| Aspect | Details |
|--------------------------------|--|
| Material | Aluminum (LUXYCLAD®) |
| Coefficient of Expansion | 5.6 mm (1/4") per 7.3 m (24 ft) for a temperature change of 30°C (86°F) |
| Typical Temperature Range | From 8°C (46°F) to 38°C (100°F), or a 30°C (86°F) change |
| Expansion/Contraction Movement | <ul style="list-style-type: none"> • Expansion: Up to 5.6 mm (1/4") over 7.3 m (24 ft) during temperature increase • Contraction: Same amount during cooling |
| Example Calculation | <ul style="list-style-type: none"> • Installed at 8°C (46°F) • Temperature rises to 38°C (100°F) • Length expands by approximately 1/8" (~3 mm) |
| Installation Recommendations | <ul style="list-style-type: none"> • Allow for movement: Fit LUXYCLAD® to the midpoint of coverage in trim pieces to facilitate expansion and contraction • Avoid confinement: Do not fasten profiles and trim profiles together, as this restricts movement • Secure properly: Install one fastener at the midpoint (through the profile fastening area) to prevent migration and buckling |
| Important Notes | <ul style="list-style-type: none"> • Confined installation at both ends can cause waving, buckling, or damage due to thermal movement • Proper installation is crucial for maintaining appearance and structural integrity over temperature variations |

Material Behavior

→ Aluminum is a highly durable yet flexible metal that responds predictably to temperature fluctuations. Its linear expansion coefficient means that even small temperature variations can produce noticeable movement in long spans of siding or soffit. Proper design and installation are essential to prevent damage such as warping, waving, or buckling.

Design and Installation Tips

→ Always leave a gap or slack at the ends of profiles to accommodate expansion and contraction.

Install fasteners at the midpoint of each profile, not at the edges, to allow free movement. Use flexible sealing or joint materials at expansion points to accommodate movement without compromising weather tightness.

Common Mistakes to Avoid

→ Over-tightening fasteners, which restrict movement and cause deformation.

Fixing profiles at both ends without allowances, leading to buckling during temperature swings.

Failing to account for seasonal temperature changes in design planning.

Industry Standards and Guidelines

→ Refer to industry standards such as the Aluminum Association's guidelines for thermal expansion or local building codes that specify expansion allowances for exterior cladding.

Understanding the Bending Radius Estimate

→ The values provided in the table are initial estimates based on the general guideline: 10 to 20 times the profile thickness. This rule is a widely used engineering principle in construction and manufacturing industries to estimate the minimum bend radius for sheet metal particularly aluminum without causing damage such as cracking, warping, or excessive deformation.

What is the Minimum Bend Radius?

It is the smallest radius a material can be bent without incurring damage. The profile thickness refers to the thickness of the sheet or profile being bent (e.g., 0.45 inches or 11.4 mm).

Why Use 10-20 Times the Profile Thickness?

- 10× (or 10 times the profile thickness): Represents a more aggressive bend, suitable for very flexible materials or profiles with high bendability. However, this comes with a higher risk of damage if the material isn't sufficiently ductile.
- 20× (or 20 times the profile thickness): Offers a safer, more conservative bend radius that minimizes the risk of cracking, deformation, or other damage, especially for less ductile aluminum.





Summary:

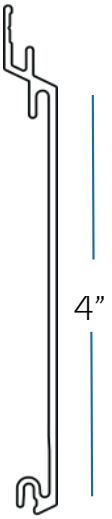

The "10-20 times the profile thickness" rule offers a practical starting point for estimating the minimum safe bend radius when working with aluminum profiles. It is important to note that these are approximate values. For precise applications, physical testing or guidance from the manufacturer should be used to confirm the optimal bend radius.

Note:

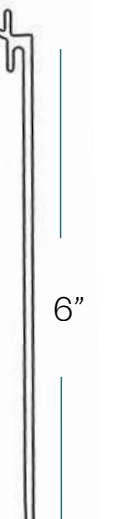
These estimates provide a useful reference for planning installation and fabrication, but actual bending should be verified through material testing or consultation with the profile manufacturer to ensure safety and integrity.

| LUXYCLAD® Profile Type / Profile Face Width | Panel/Material Thickness (approx.) | Calculation (Thick x 10-20) | Estimated Minimum Bend Radius | Remarks |
|---|------------------------------------|---|-------------------------------|--|
| 4" Profile | 0.45" (11.4 mm) | 0.45" x 10 = 4.5" 0.45"x 20 = 9" | 6" | Conservative estimate (~10x thickness) |
| 6" Profile | 0.47" (11.9 mm) | 0.47" x 10 = 4.7" 0.47"x 20 = 9.4" | 6.5" | Use 10x for practical bending |
| 6" Channel | 0.45" (11.4 mm) | 0.45" x 10 = 4.5" 0.45"x 20 = 9" | 6" | Conservative estimate (~10x thickness) |
| Perforated 4" V- Groove soffit | 0.47" (11.9 mm) | 0.47" x 10 = 4.7" 0.47"x 20 = 9.4" | 6.5" | Similar to V-Groove profiles |
| Flat Cap | ~0.55" (14 mm) | 0.55" x 10 = 5.5" 0.55"x 20 = 11" | 8" | Larger profile, more flexibility |
| 1" Outside Corner | 0.53" (13.5 mm) | 0.53" x 10 = 5.3" 0.53"x 20 = 10.6" | 8" | Standard corner profile |
| 1.7" Outside Corner | 0.66" (16.6 mm) | 0.66" x 10 = 6.6" 0.66" x 20 = 13.2" | 10" | Larger corner, bigger radius |
| 1" Inside Corner | 0.51" (13 mm) | 0.51" x 10 = 5.1" 0.51"x 20 = 10.2" | 8" | Typical inside corner |
| Flat Trim Base | 0.47" (11.9 mm) | 0.47" x 10 = 4.7" 0.47"x 20 = 9.4" | 6.5" | Trim base profile |

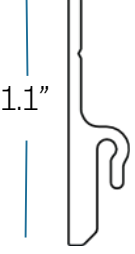
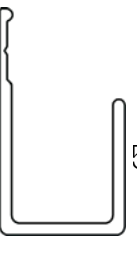
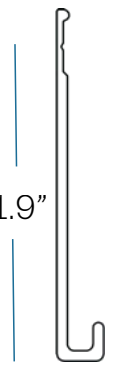
| V-Groove Perforated Soffit LENGTH: 12' | V-Groove Siding & Soffit LENGTH: 24' | V-Groove Siding & Soffit LENGTH: 24' | Flush Panel LENGTH: 24' | Channel LENGTH: 24' |
|---|---|---|--|---|
|  |  |  |  |  |

| Rain Screen clip LENGTH: 12' | J-Trim LENGTH: 12' | Starter Strip LENGTH: 12' | Splicer LENGTH: 12' |
|---|---|---|---|
|  |  |  |  |

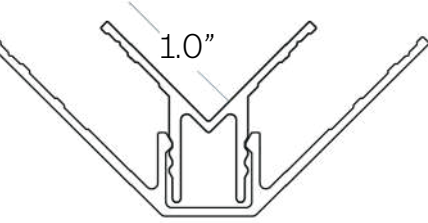
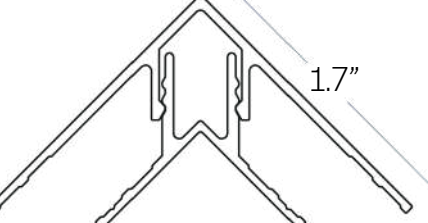
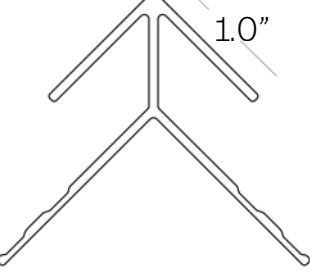
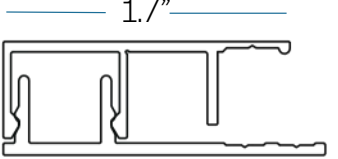
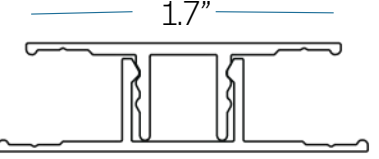
| Inside Corner LENGTH: 12' | Outside Corner 2 Piece LENGTH: 12' | Outside Corner 1 Piece LENGTH: 12' | Finishing Strip LENGTH: 12' | Flat cap LENGTH: 12' |
|--|---|---|--|---|
|  |  |  |  |  |

New 1" Precision Trims

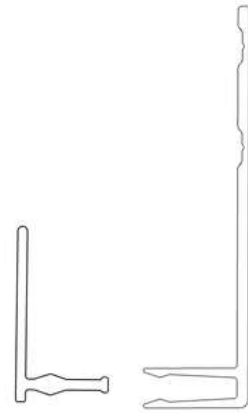
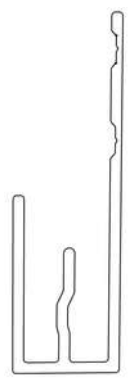
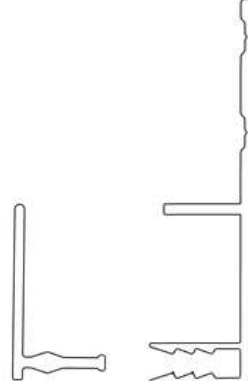
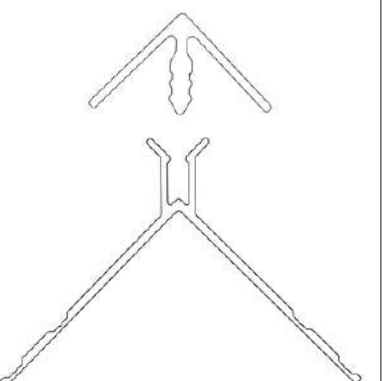
| J-Trim LENGTH: 12' | J-Trim Base + Cap LENGTH: 12' | J-Trim Starter Strip LENGTH: 12' | Finishing Cap + Base LENGTH: 12' | Outside Corner + Base LENGTH: 12' |
|---|---|---|---|---|
|  |  |  |  |  |

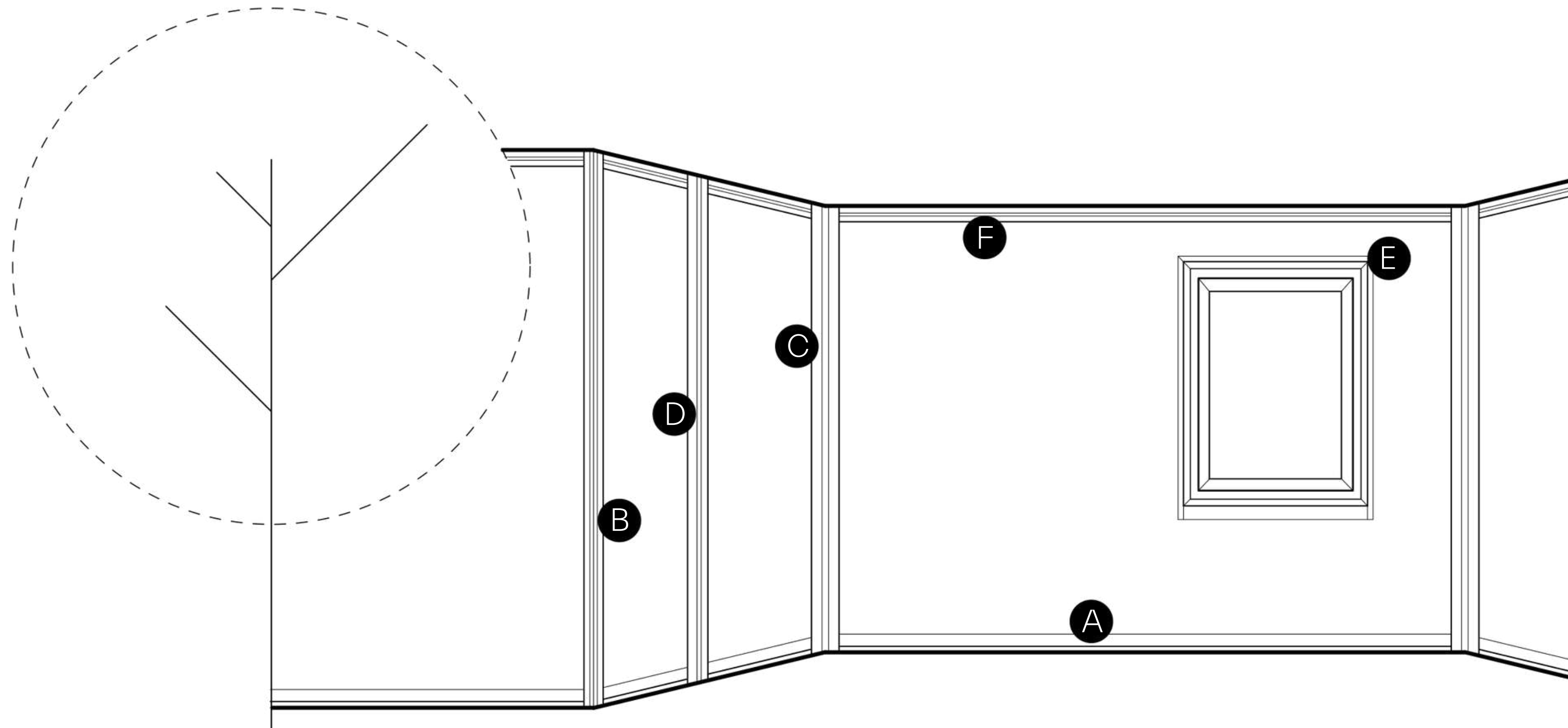

- A** STARTER STRIP & V-GROOVE SIDING
- B** OUTSIDE CORNER
- C** INSIDE CORNER
- D** FLAT CAP
- E** J-TRIM
- F** FINISHING CAP

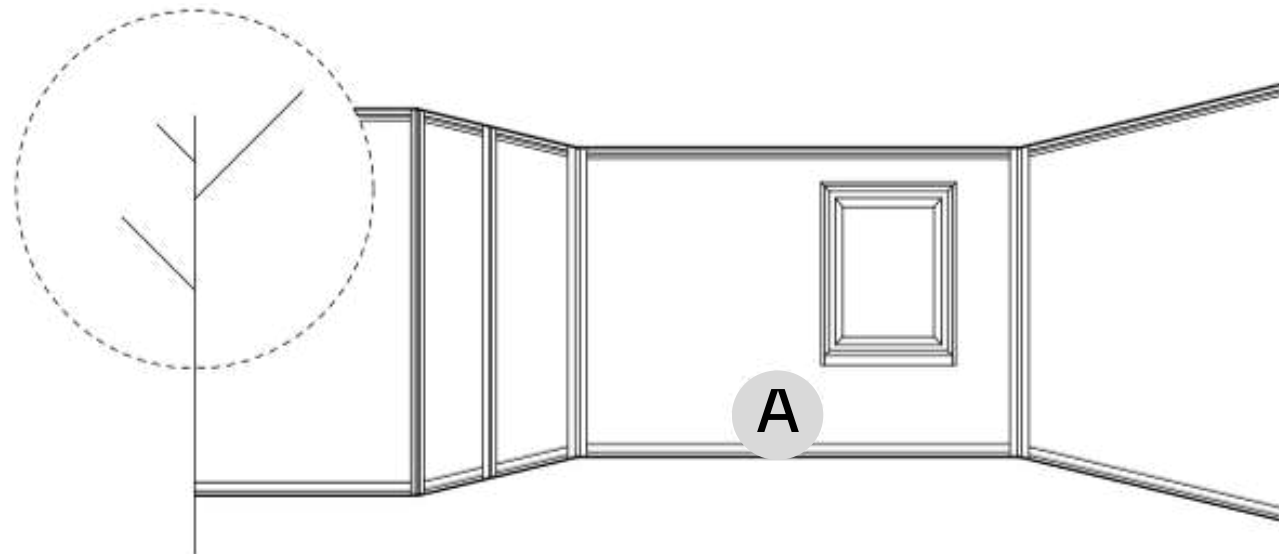

STARTER STRIP & V-GROOVE SIDING

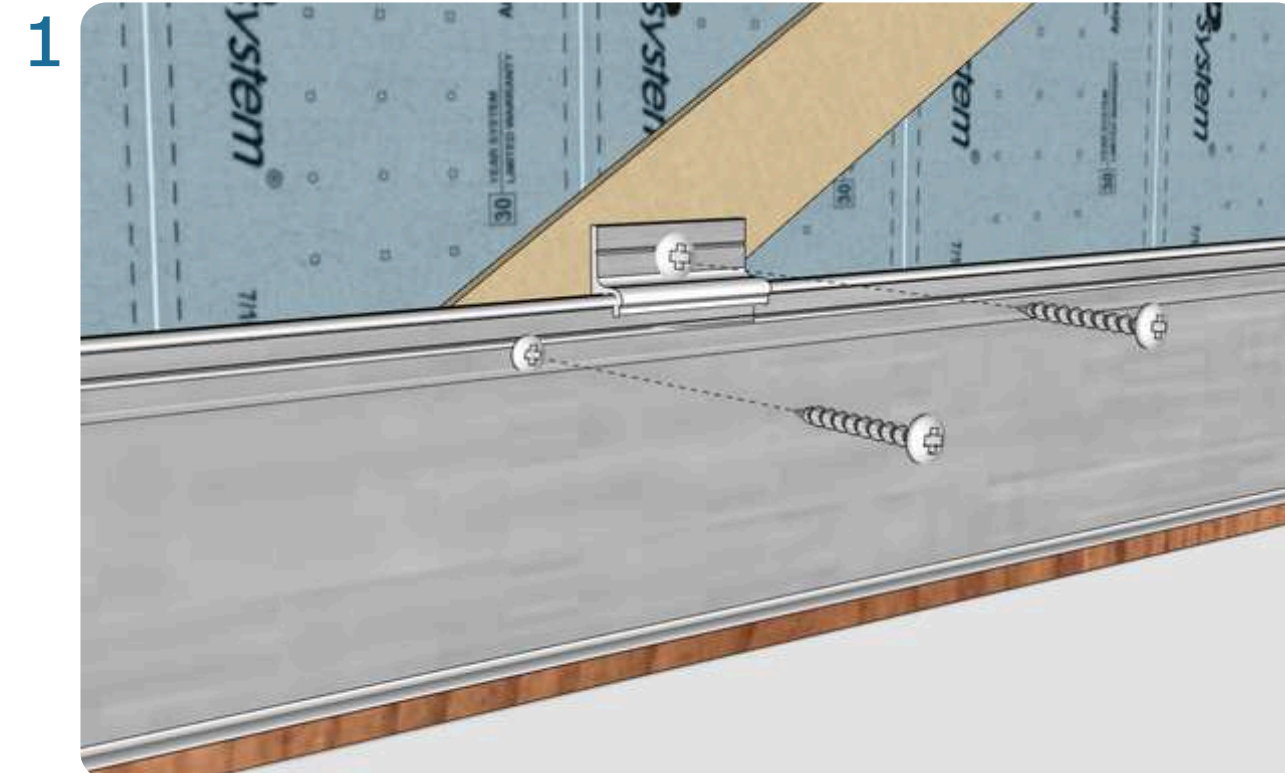

1 Hard fastening LUXYCLAD® Starter Strip with rain screen clips every 16" on center for proper ventilation. Add an additional screw next to each clip to support the load of cladding.



2 Insert siding into the starter strip and apply downward pressure on the board while securing the rain-screen clip, and then fasten the board with the rain-screen clip and screw.

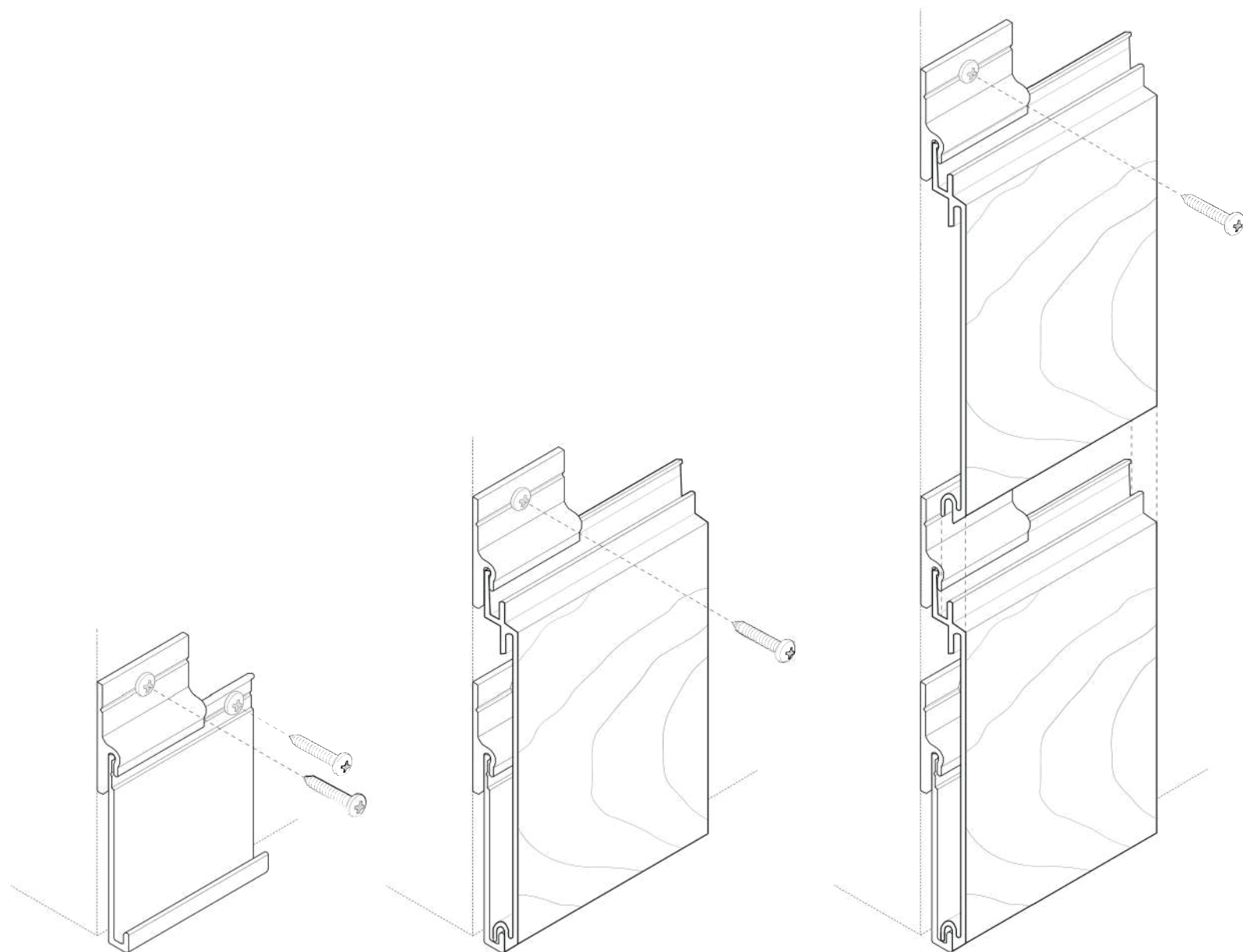

3 Continue with all the siding until completed

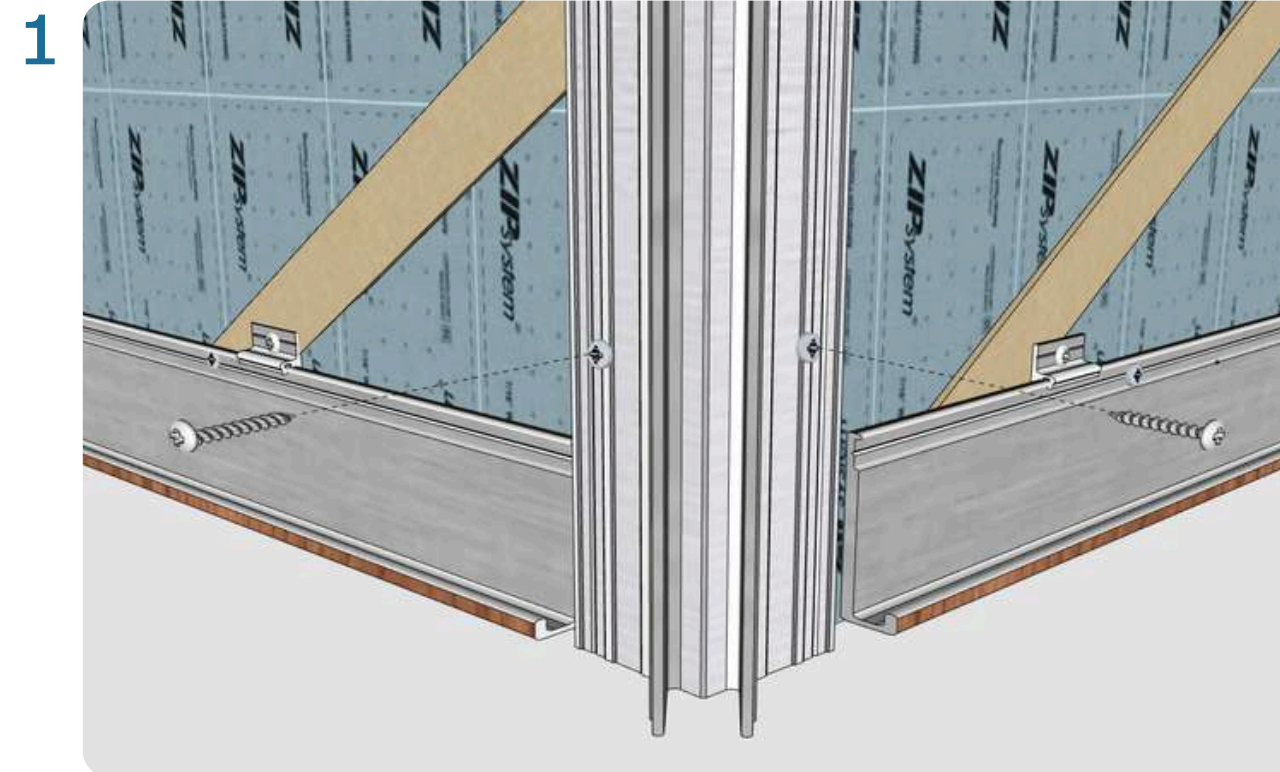
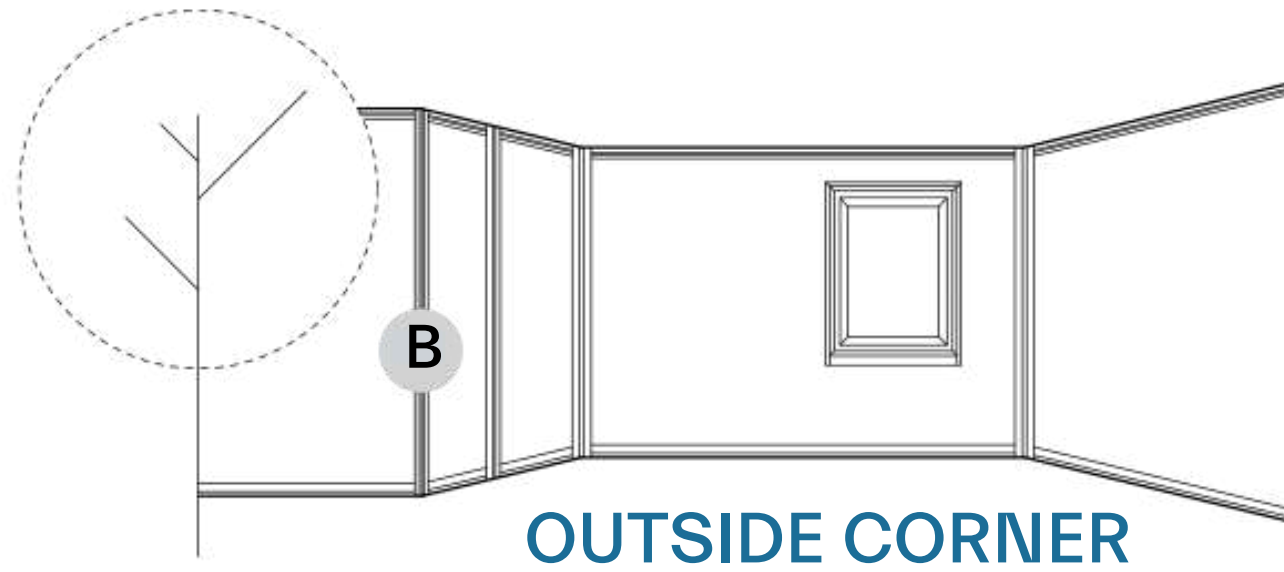

Hard fastening the LUXYCLAD® Outside Corner Base with #8 Pan Head Screws.
Hard fastening LUXYCLAD® Starter Strips with rain screen clips every 16" on center for proper ventilation.

NOTE: Do not overlap Starter Strip on Outside Corner Base.

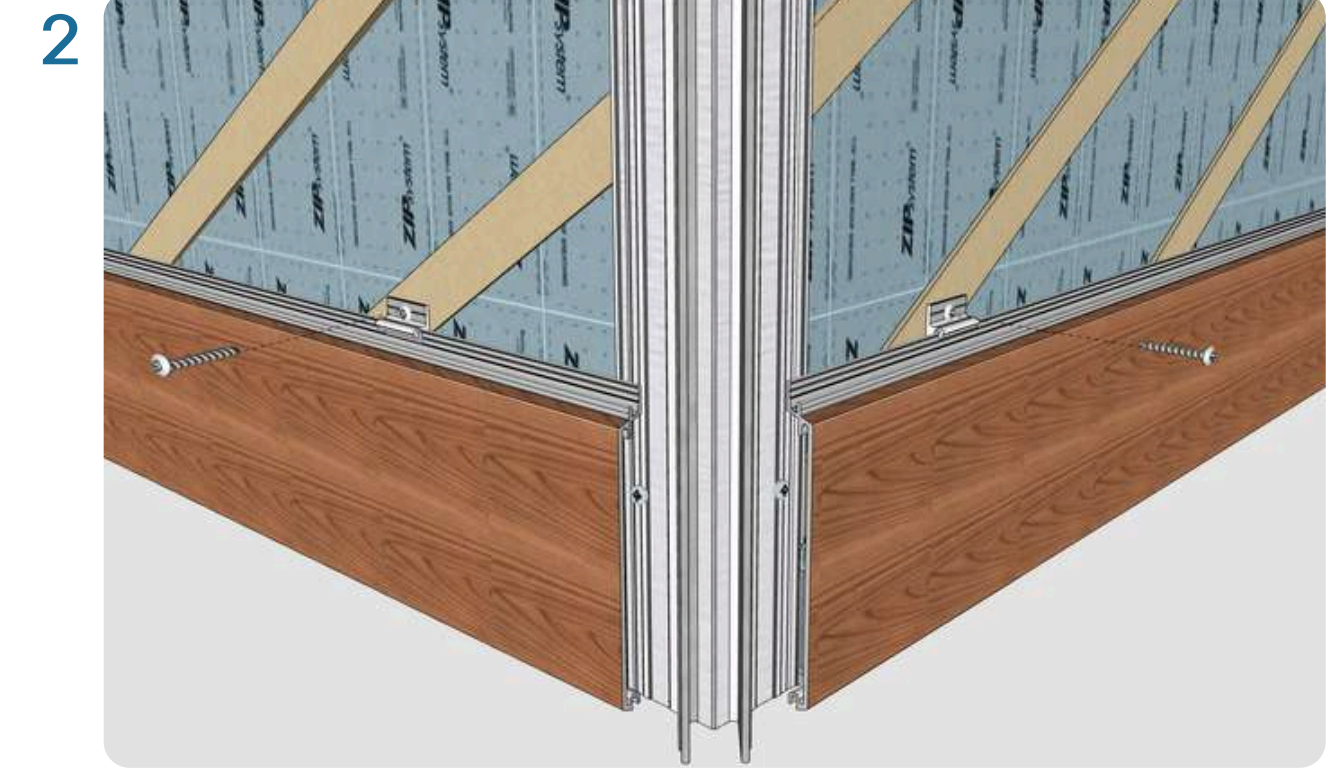

Ensure that screws do not interfere with top support of siding piece by drilling screws below alignment of top support or setting screws flush into trim base.

Continue with all the siding until completed.

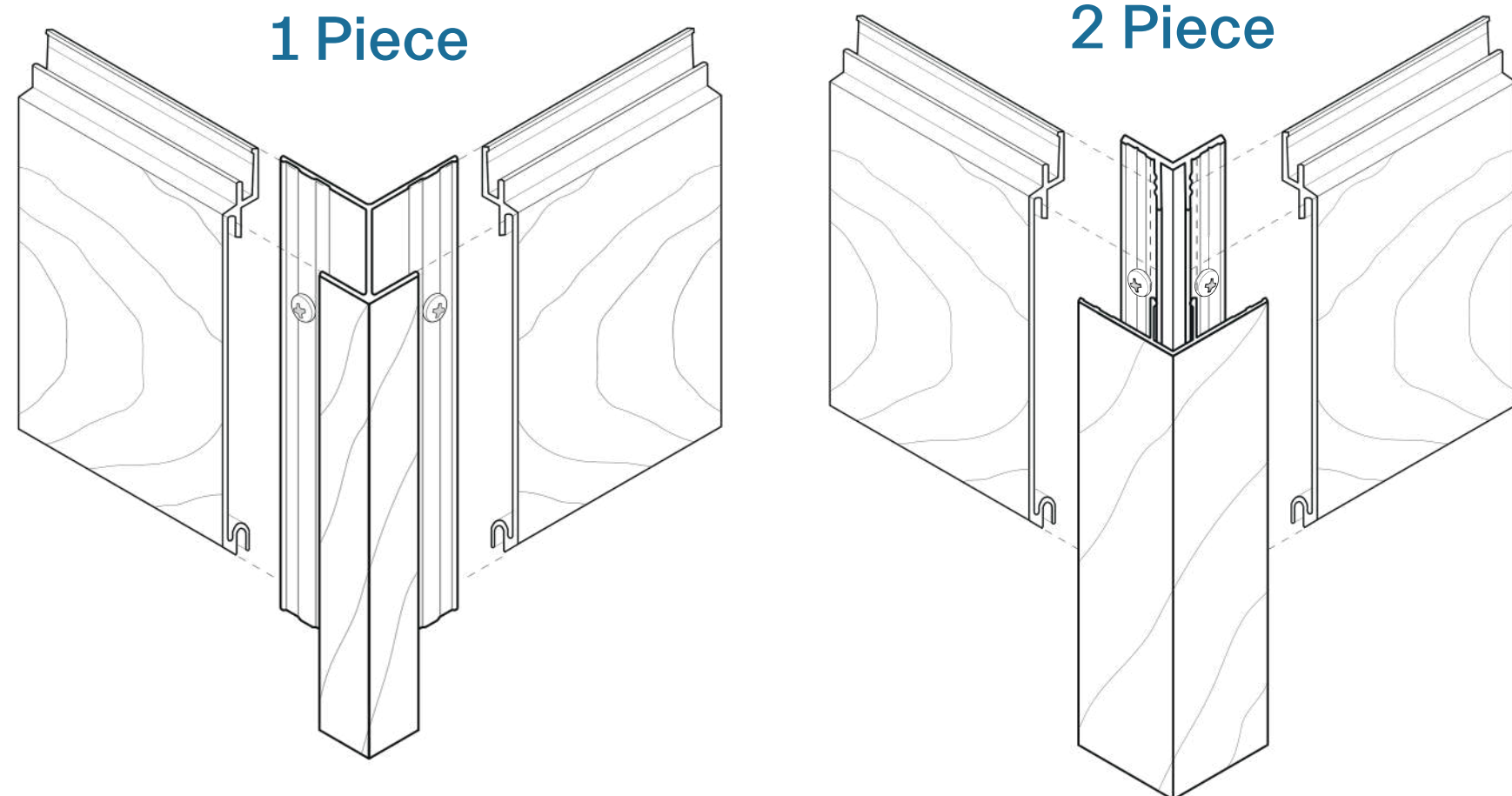

Apply the final Outside Corner Cap.
Be sure to use a tool that will not damage the finish, when driving the Outside Corner Cap into the Outside Corner Base.

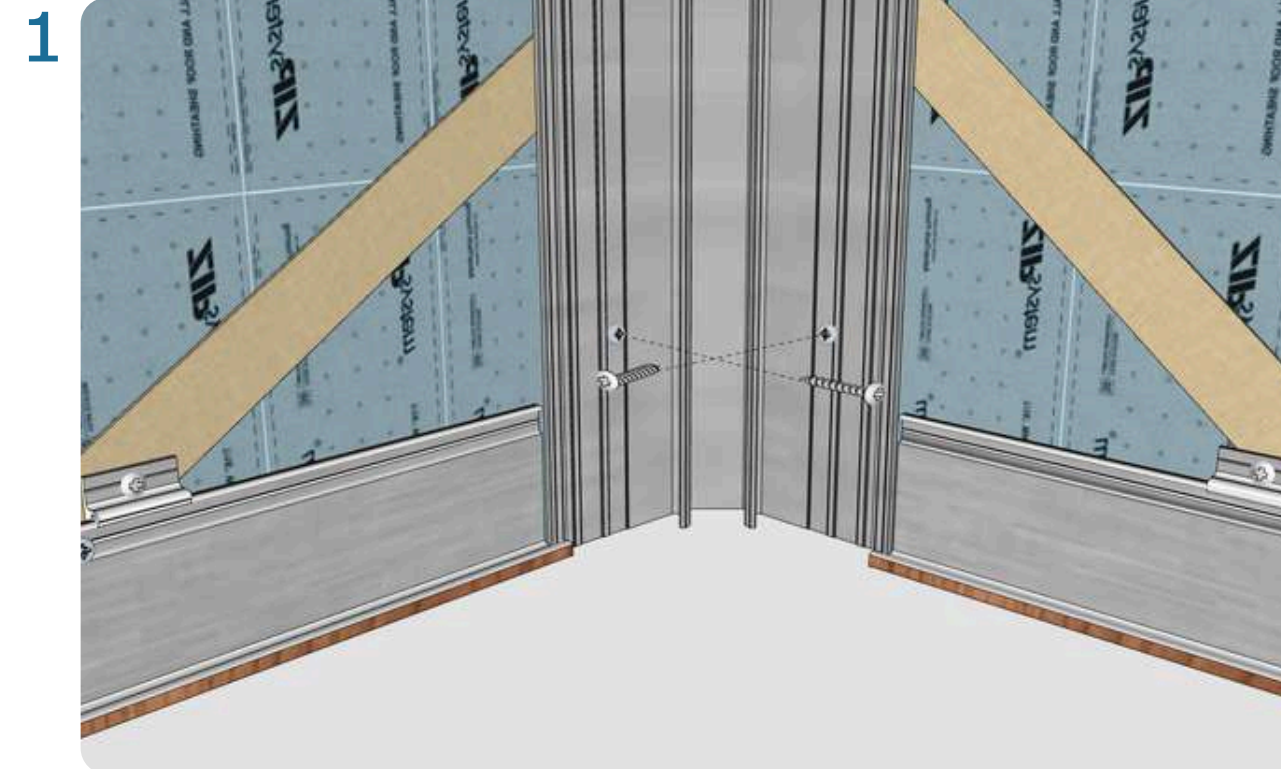
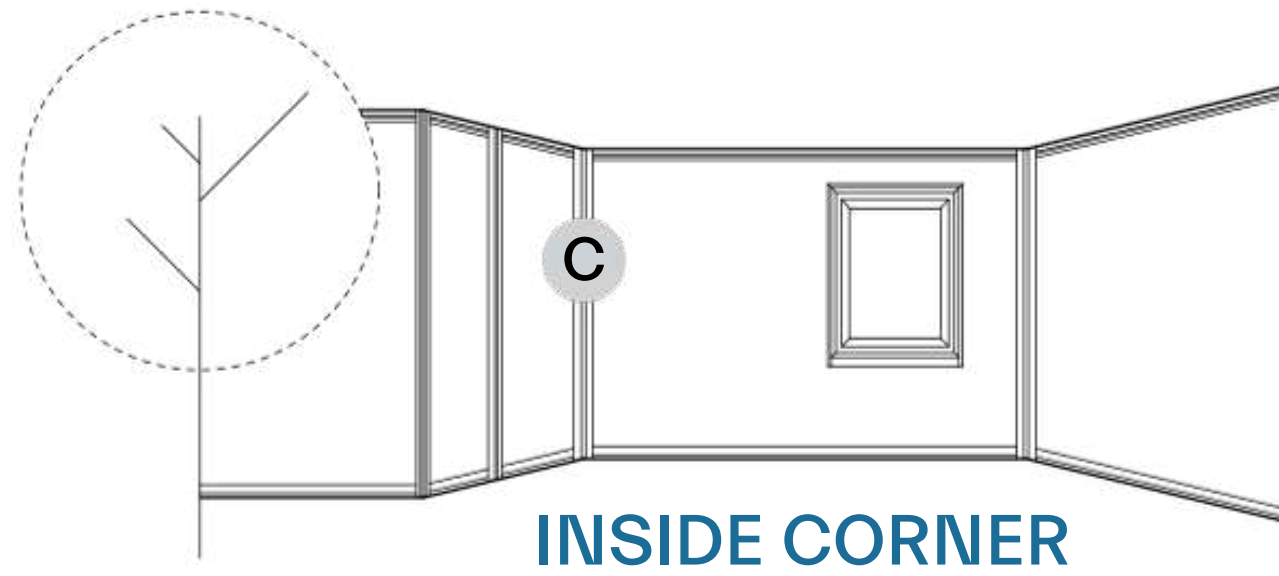

Hard fastening the LUXYCLAD® Inside Corner Base with #8 Pan Head Screws.
Hard fastening LUXYCLAD® Starter Strips with rain screen clips every 16" on center for proper ventilation.

NOTE: Do not overlap Starter Strip on Inside Corner Base.

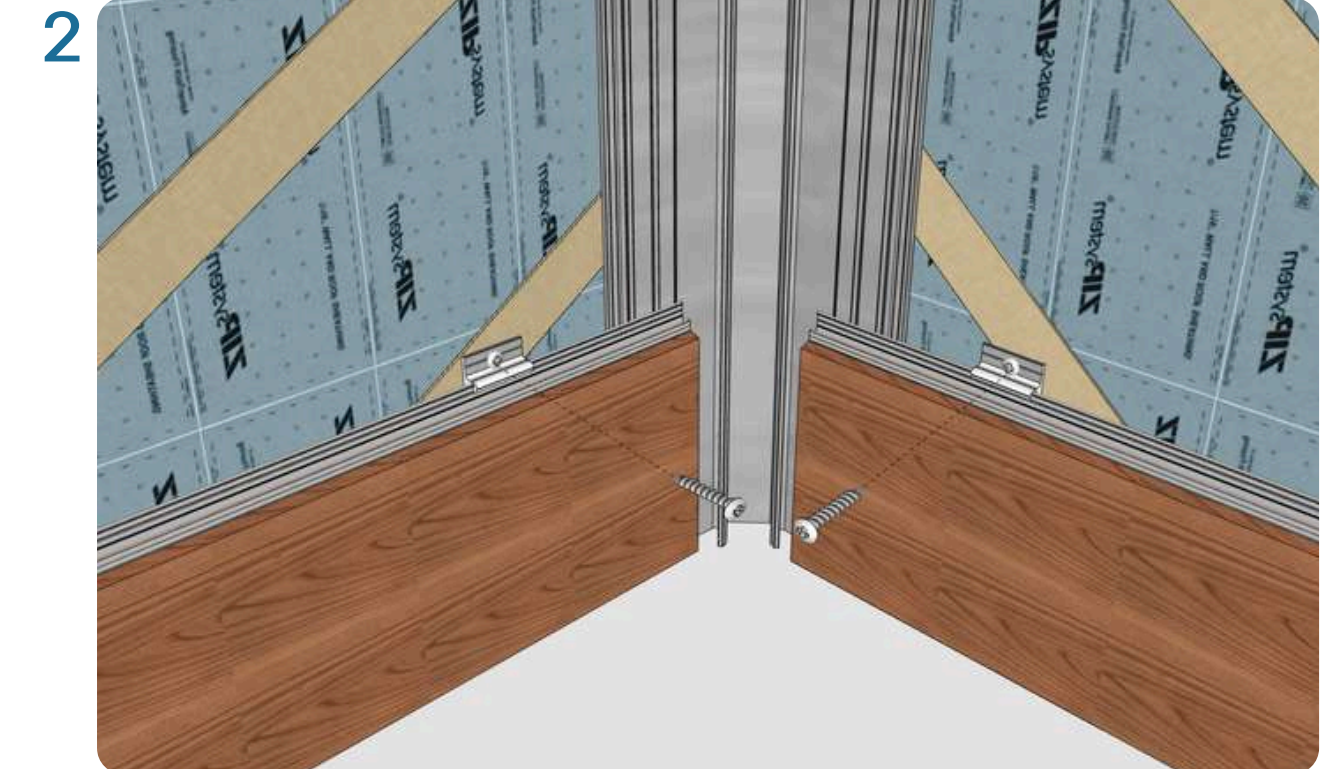

Ensure that screws do not interfere with top support of siding piece by drilling screws below alignment of top support or setting screws flush into trim base.

Continue with all the siding until completed.

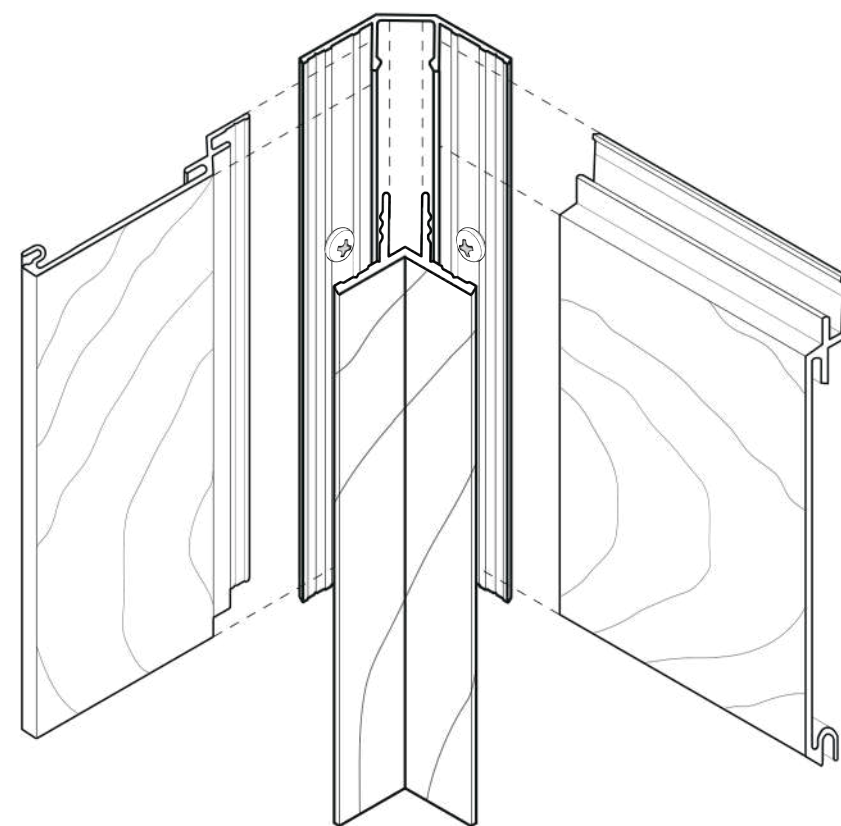

Apply the final Inside Corner Cap.
Be sure to use a tool that will not damage the finish, when driving the Inside Corner Cap into the Inside Corner Base.

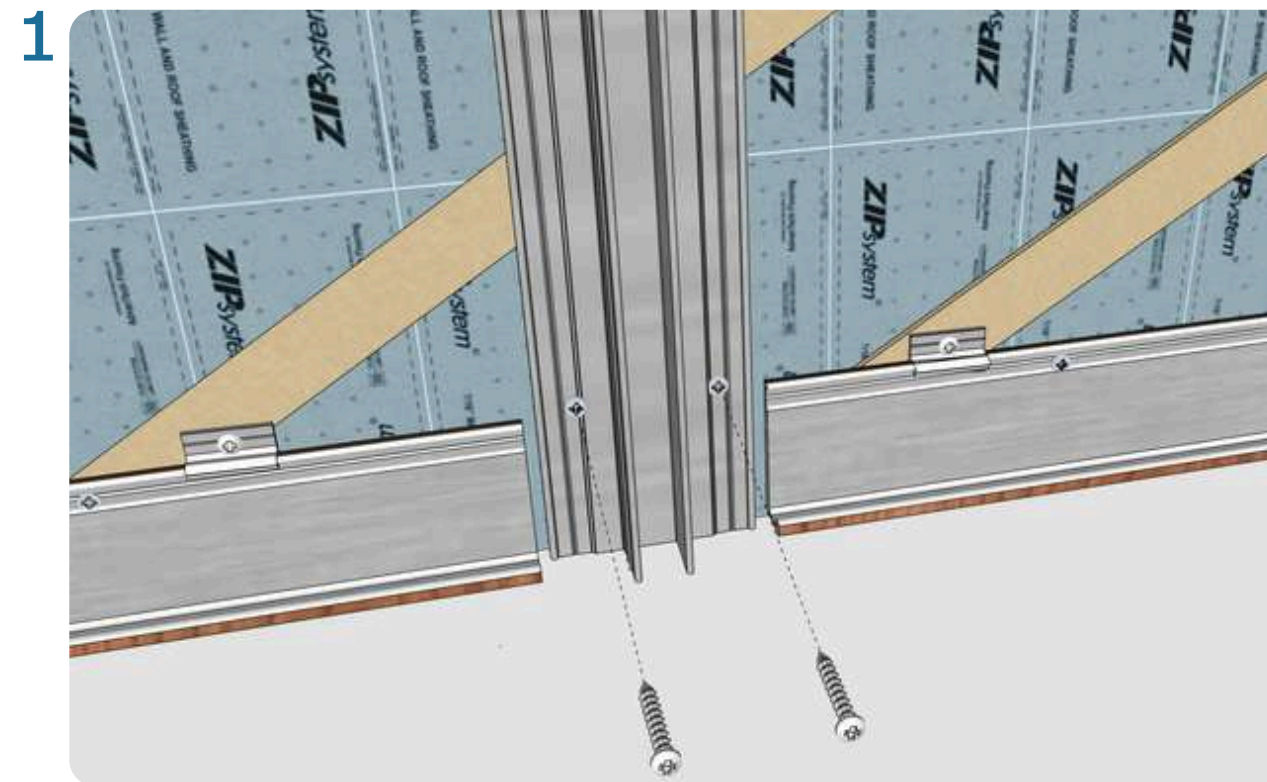
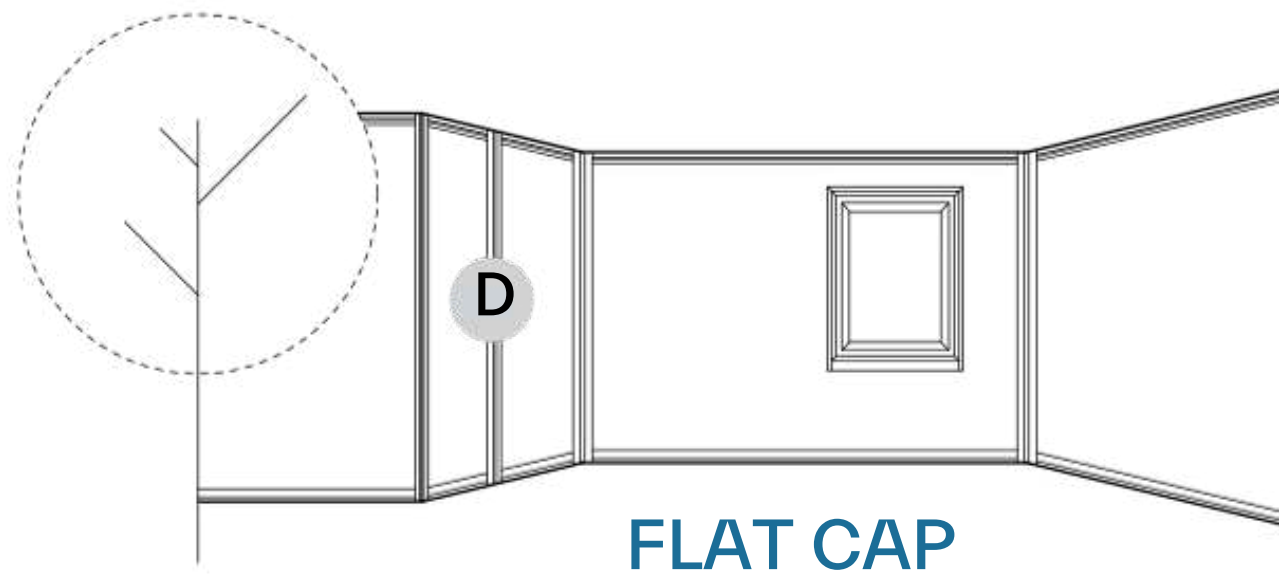

The LUXYCLAD® 1.7" flat cap & base system conceals areas where two pieces of siding meet and is recommended for spans of siding over 24" long. The base piece is fastened to the wall prior to siding with #8 Pan Head Screws.

NOTE: Do not overlap Starter Strip on Flat Base.

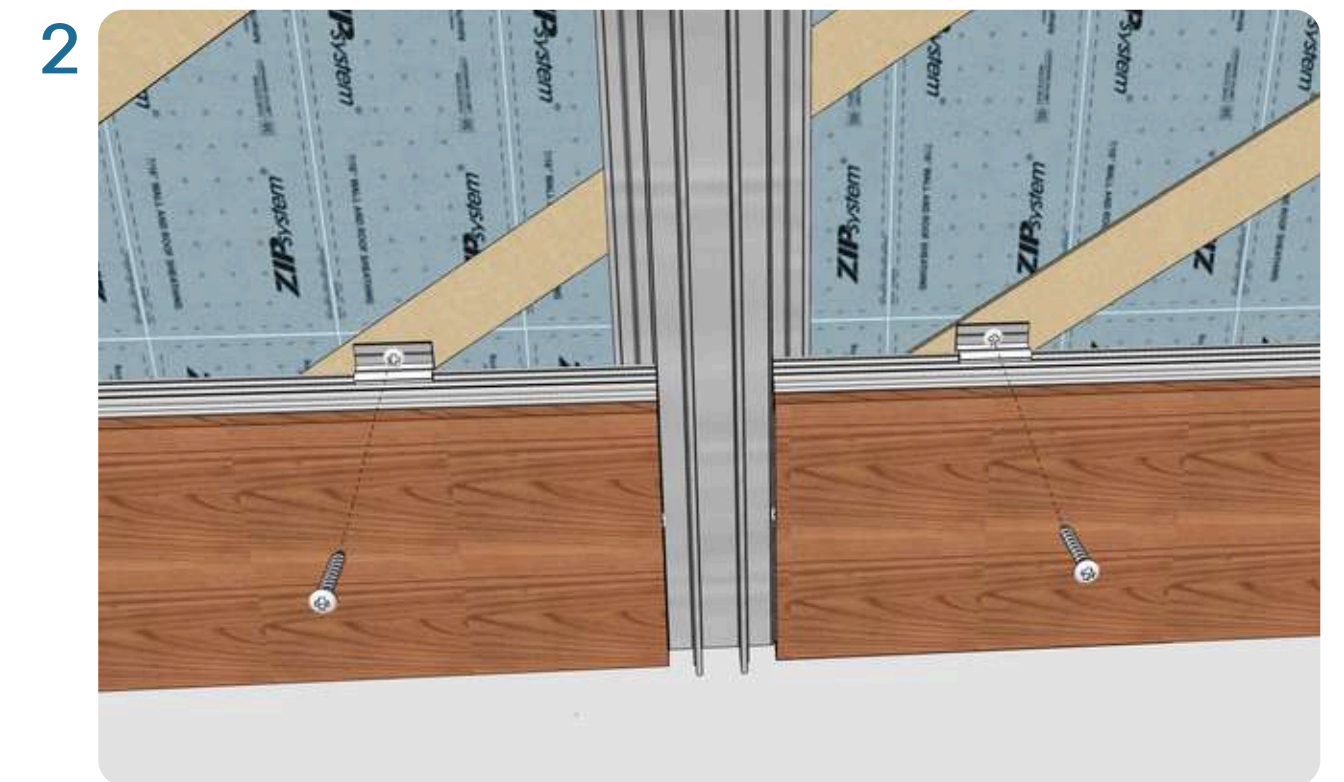

Ensure that screws do not interfere with top support of siding piece by drilling screws below alignment of top support or setting screws flush into trim base.

Continue with all the siding until completed.

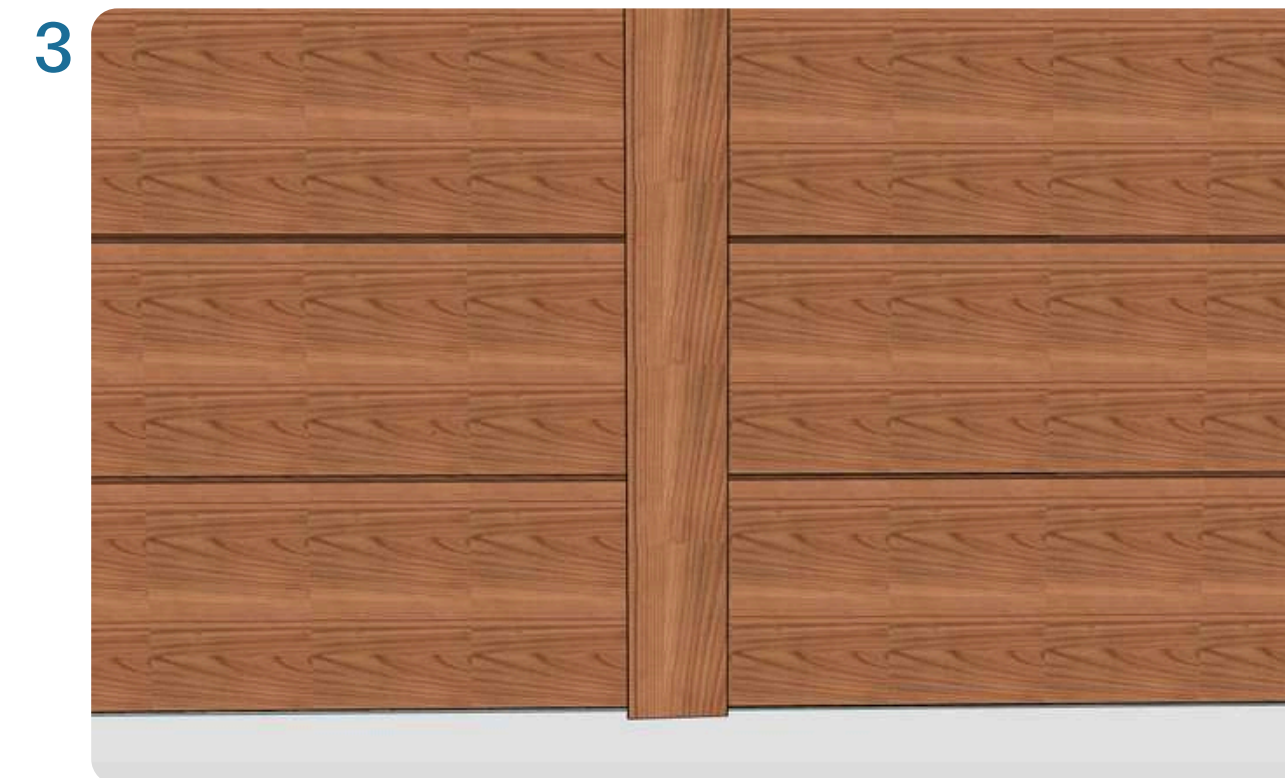
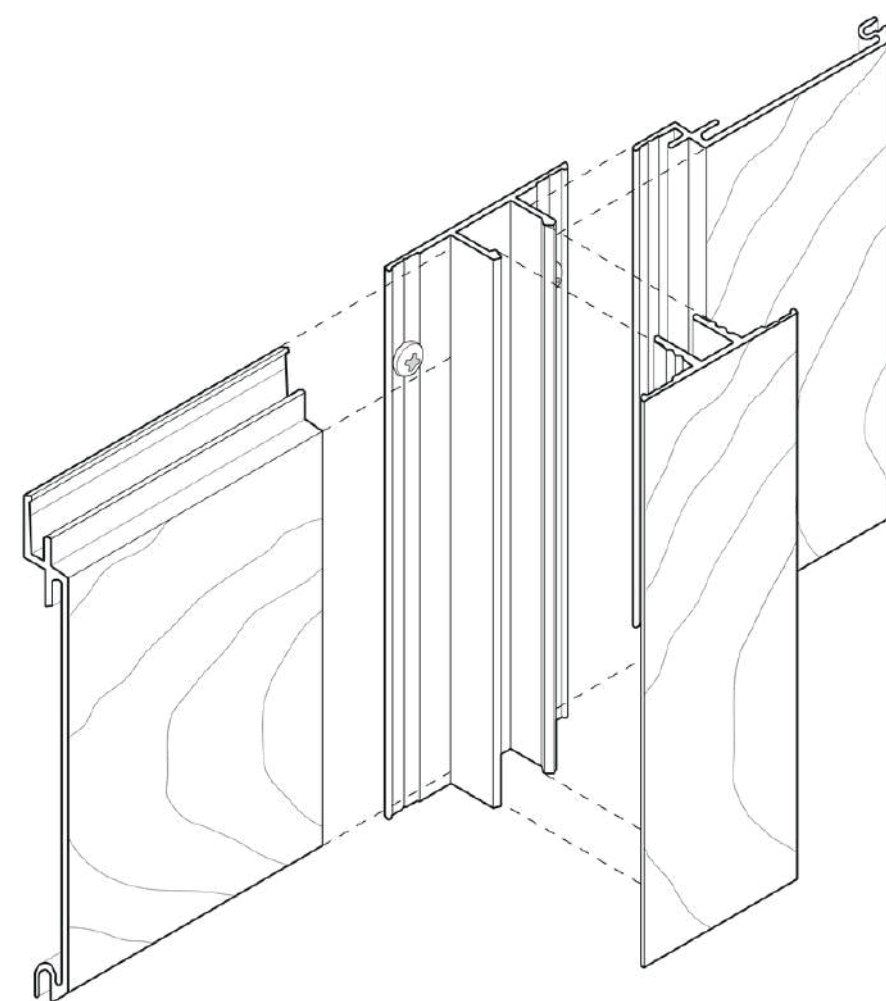

Apply the final Flat Cap. Be sure to use a tool that will not damage the finish, when driving the Flat Cap into the Flat Cap Base.

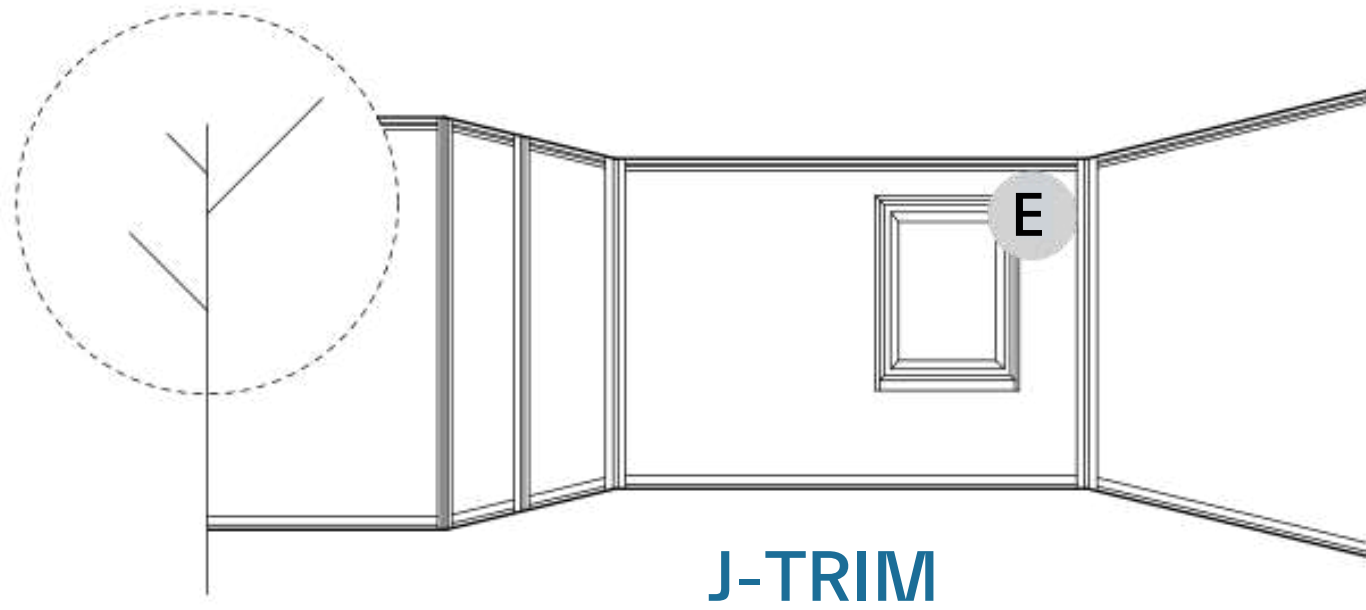

Cut out on the Trim

J-trim is used as a trim around windows, doors, or any other openings in the wall. This trim can also be used to finish runs of siding at tops and sides of walls, or as a corner reveal. Hard fastening the LUXYCLAD® J-Trims with #8 Pan Head Screws.

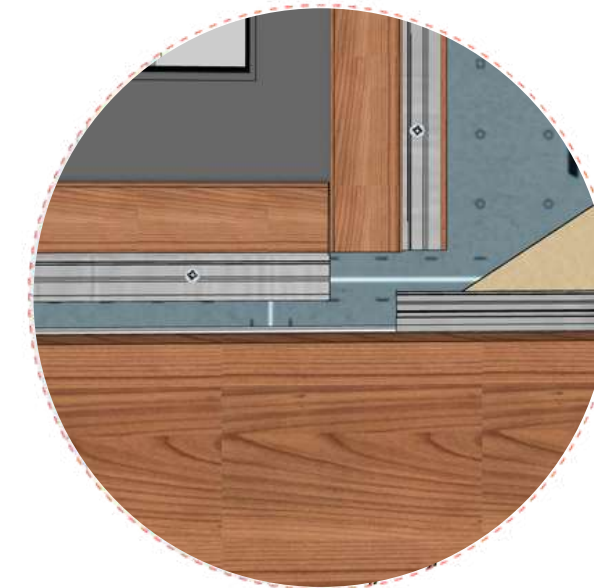

Secure the rain- screen clip, and then fasten the board with the rain-screen clip and screw.

Note: Top support of first siding board must be cut to rest inside J-trim.

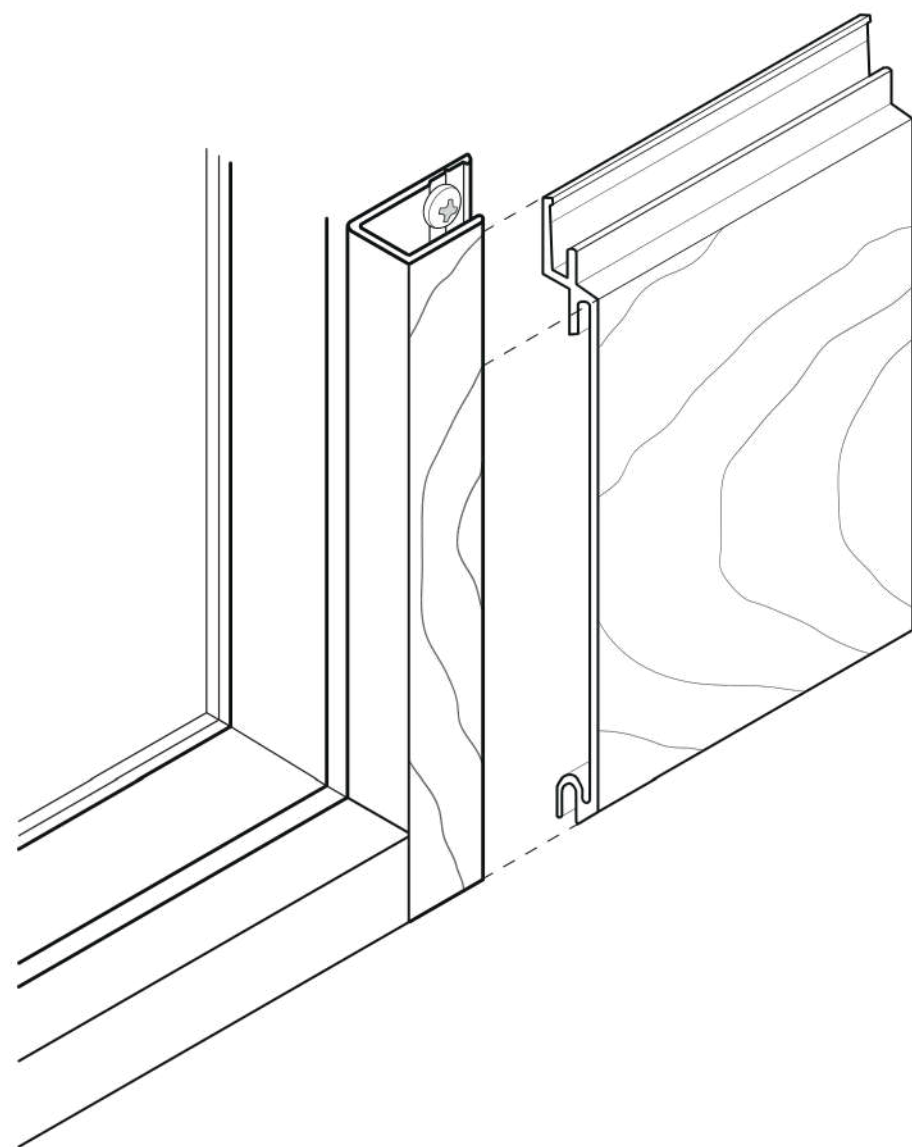

Continue with all the siding until completed.

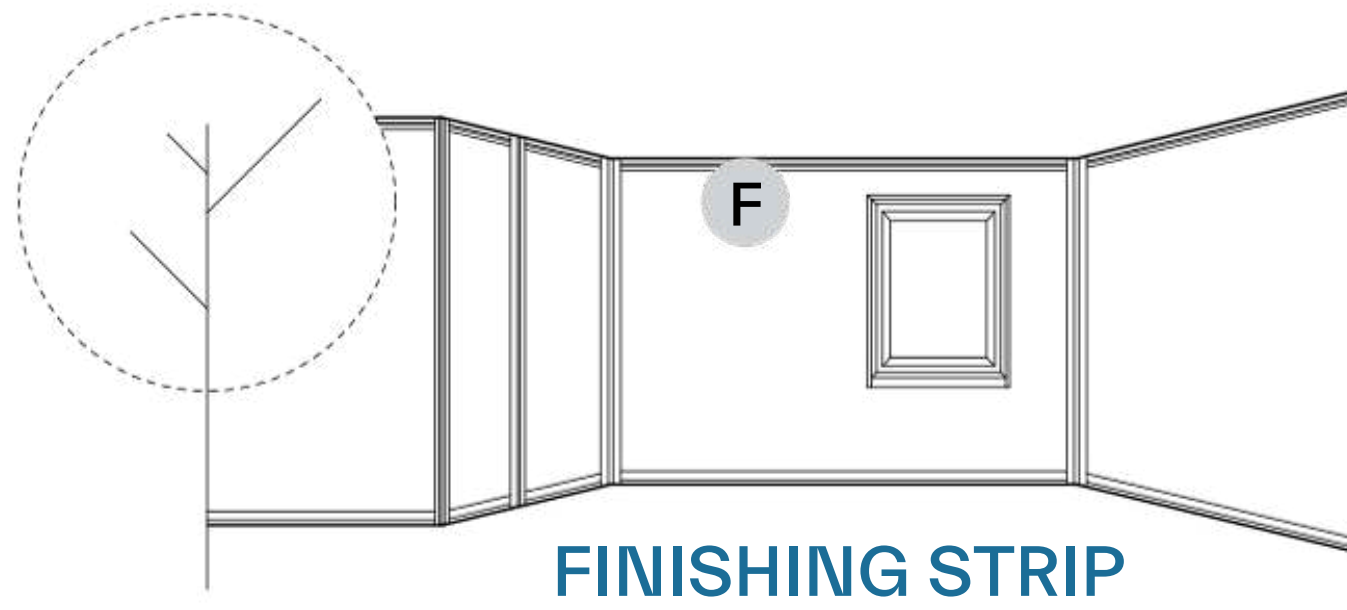

1

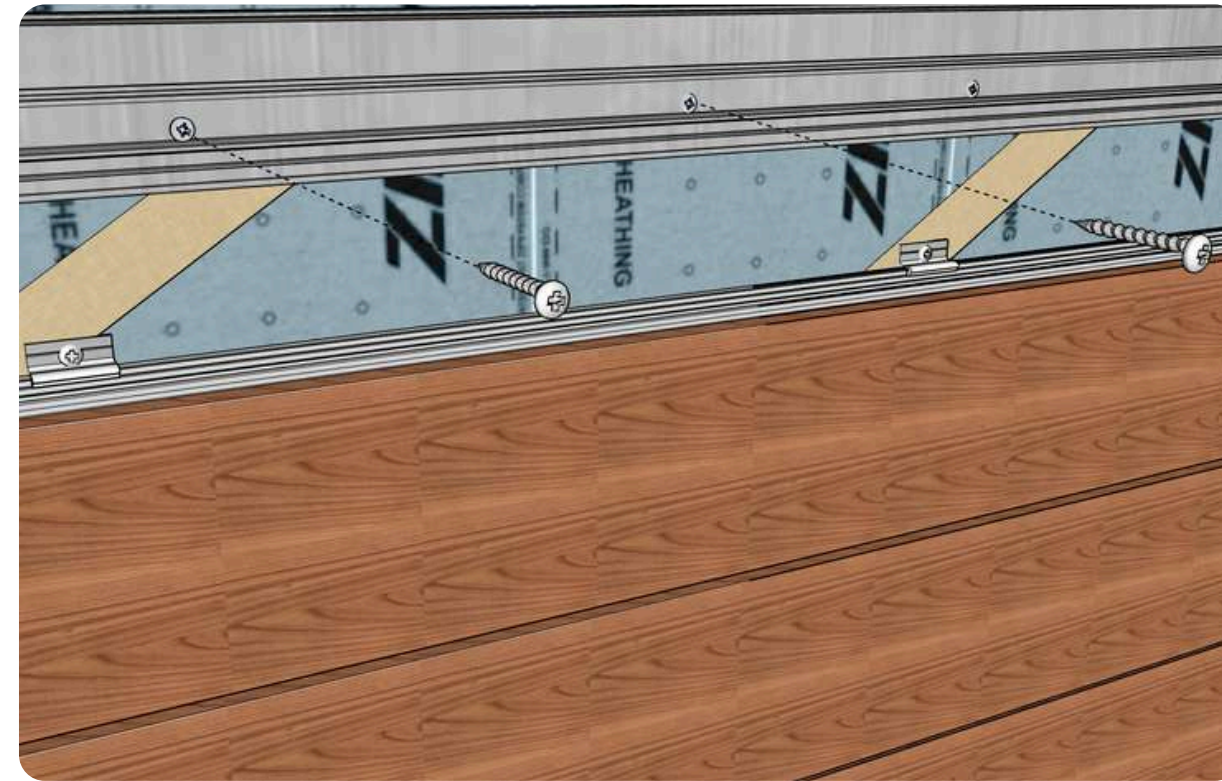

Once the wall and soffit are completed, hard fasten the finishing base and the final piece of siding.

2

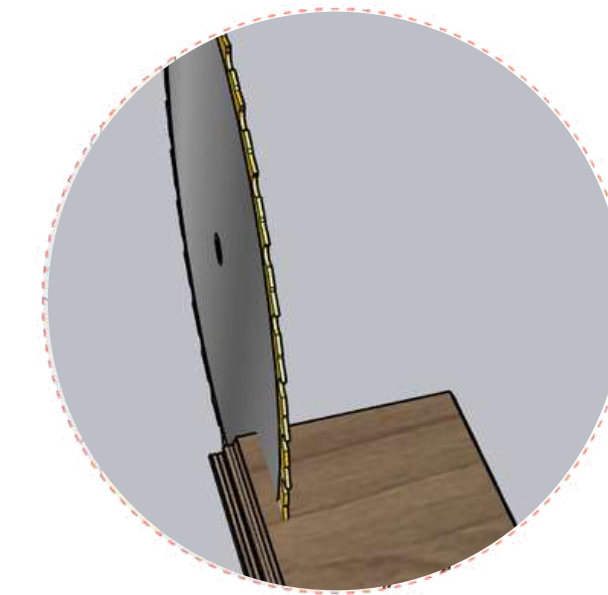

Note:
This last piece of siding may need to be ripped

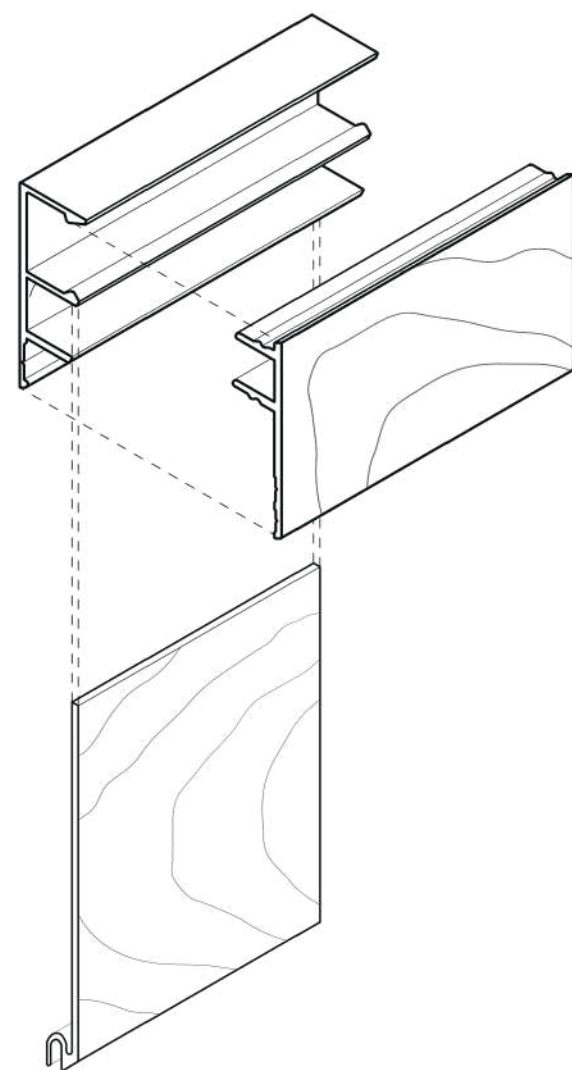

3

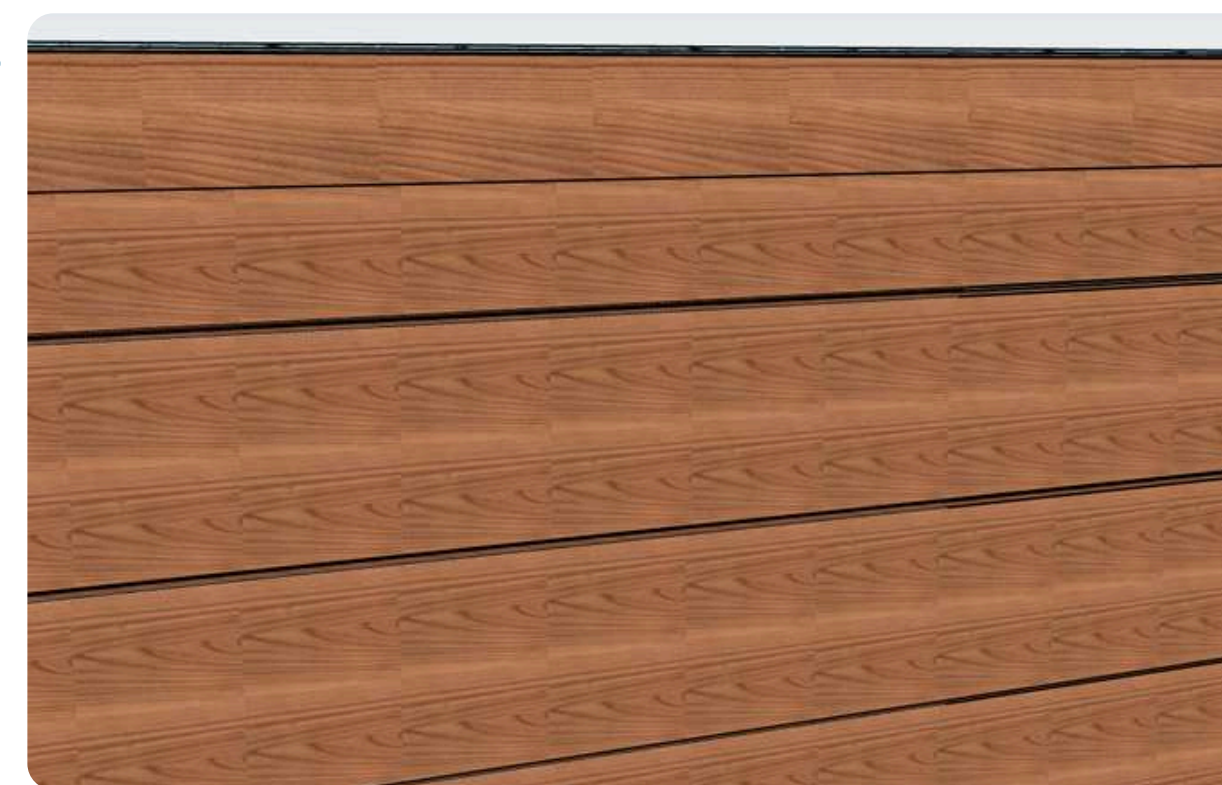

Apply the final Finishing cap. Be sure to use a tool that will not damage the finish, when driving the Finishing cap into the Finishing base.

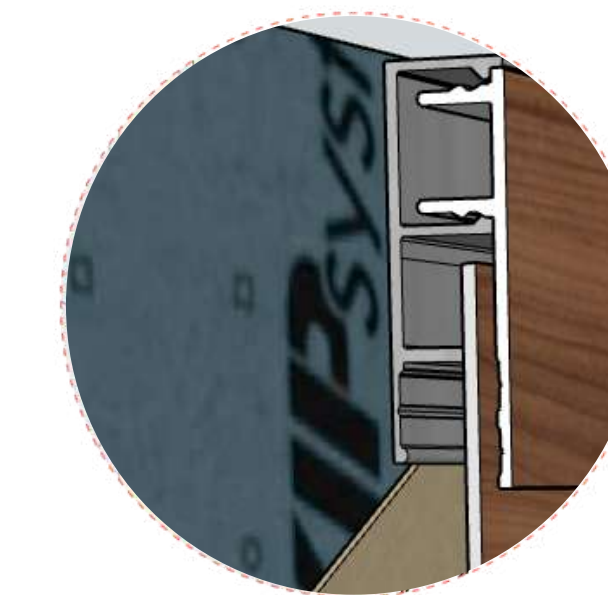

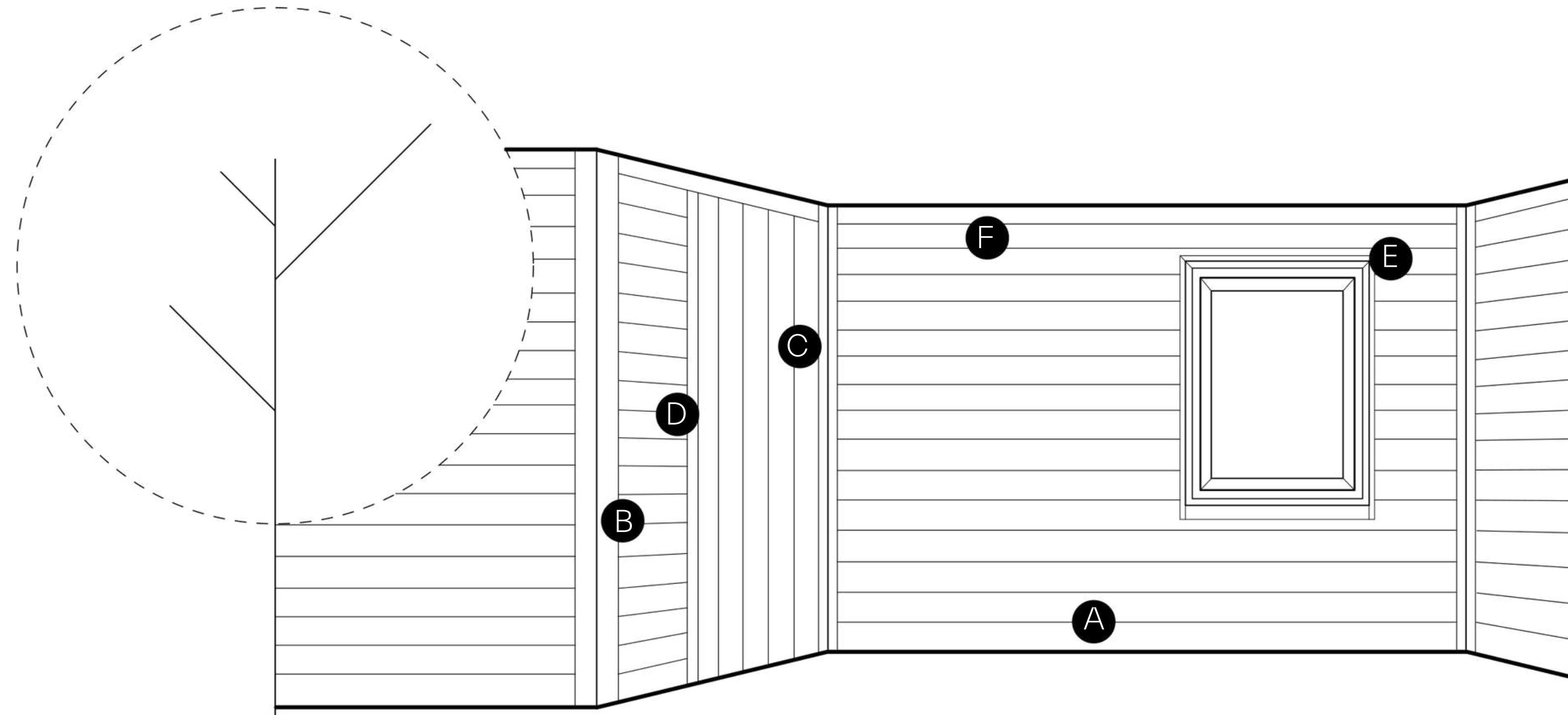

- A** STARTER STRIP & V-GROOVE SIDING
- B** OUTSIDE CORNER
- C** INSIDE CORNER
- D** FLAT CAP
- E** J-TRIM
- F** FINISHING CAP

1" PRECISION STARTER STRIP & V-GROOVE SIDING

The LUXYCLAD® 1" Precision Starter Strip is used to initiate the installation of V-Groove siding in either a horizontal or vertical orientation. The siding profile sits securely within the strip, which is fastened directly to the substrate and integrated through the rain screen clips for a high-performance, moisture-managed assembly.

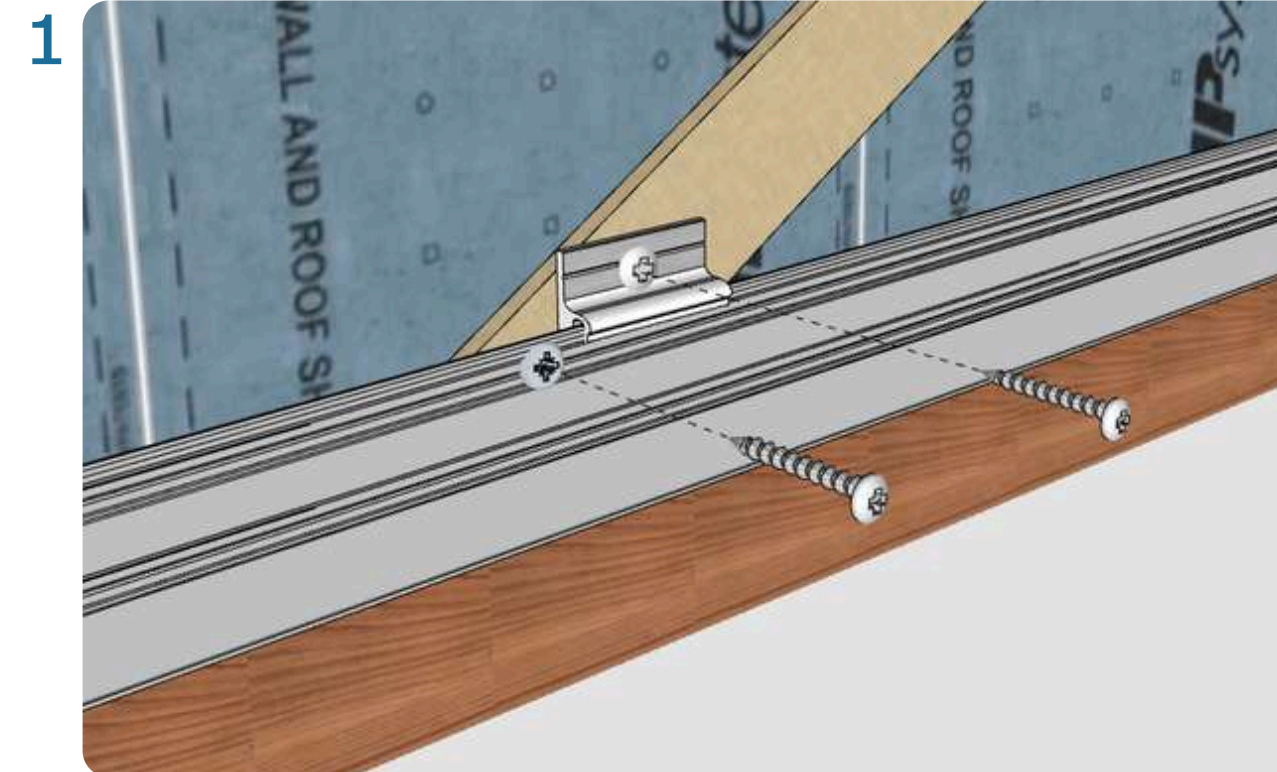

1 Hard fastening LUXYCLAD® 1" precision Starter Strip with rain screen clips every 16" on center for proper ventilation. Add an additional screw next to each clip to support the load of cladding.



2 Insert siding into the 1" precision starter strip and apply downward pressure on the board while securing the rain-screen clip, and then fasten the board with the rain-screen clip and screw.



Continue with all the siding until completed.

1" PRECISION FINISHING CAP + BASE

The LUXYCLAD® 1" Precision Finishing Strip is a versatile two-piece system designed to provide a simple, clean accessory for terminating runs of siding. This architectural trim ensures a seamless finish where the cladding meets a transition point or wall end, with the decorative cap snapping securely into the base for a precise fit.

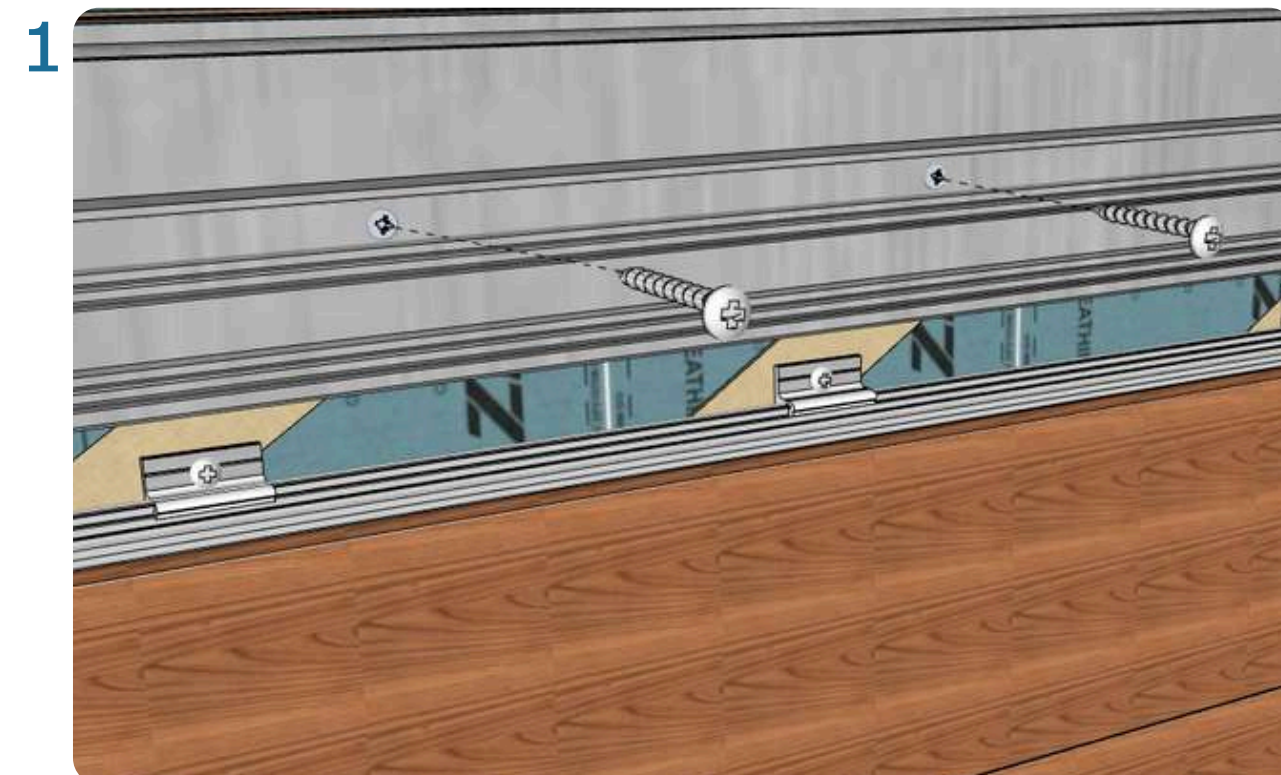
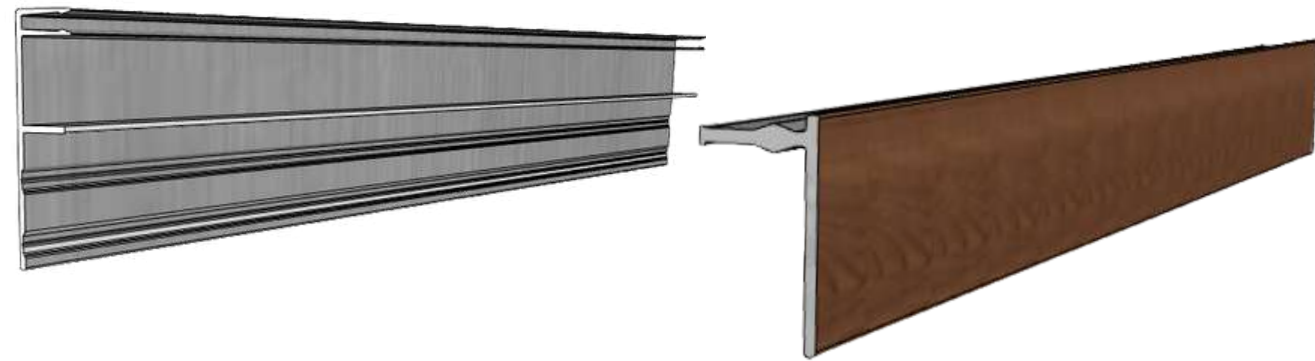

Once the wall and soffit are completed, hard fasten the LUXYCLAD® 1" precision finishing base and the final piece of siding.



Note: This last piece of siding may need to be ripped.

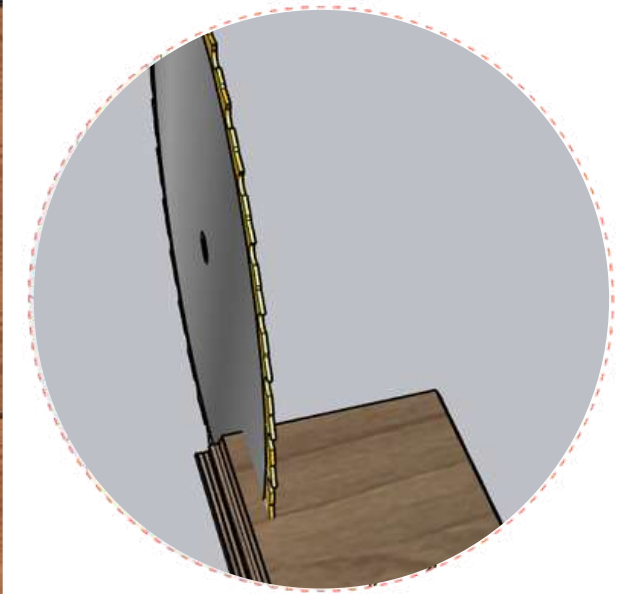

Apply the final 1" precision Finishing cap. Be sure to use a tool that will not damage the finish, when driving the 1" precision Finishing cap into the 1" precision Finishing base.

1" PRECISION J-TRIM BASE + CAP

The LUXYCLAD® 1" Precision J-Trim (Base + Cap) is a versatile solution for trimming around doors and other wall openings. This two-piece system is also ideal for finishing siding runs at the tops and sides of walls, or for creating a clean corner reveal. For a seamless installation, the decorative cap easily snaps directly into the base piece.

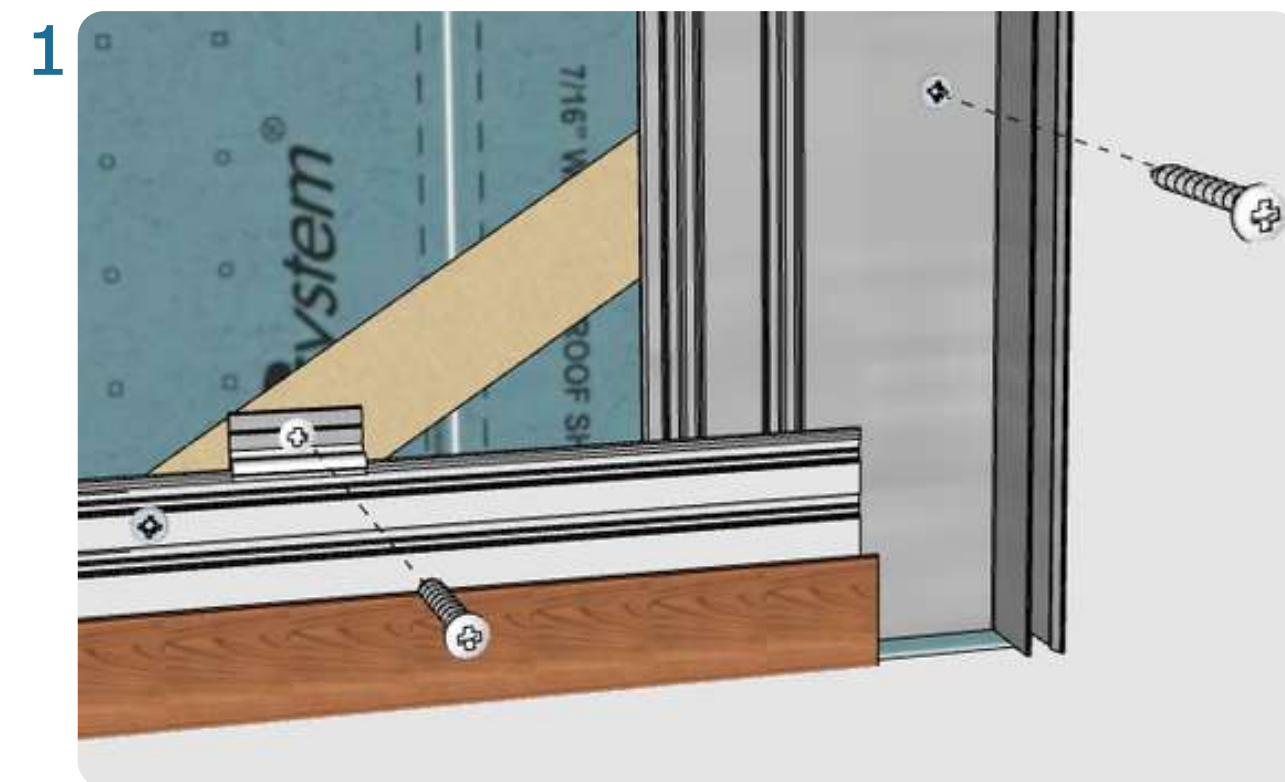
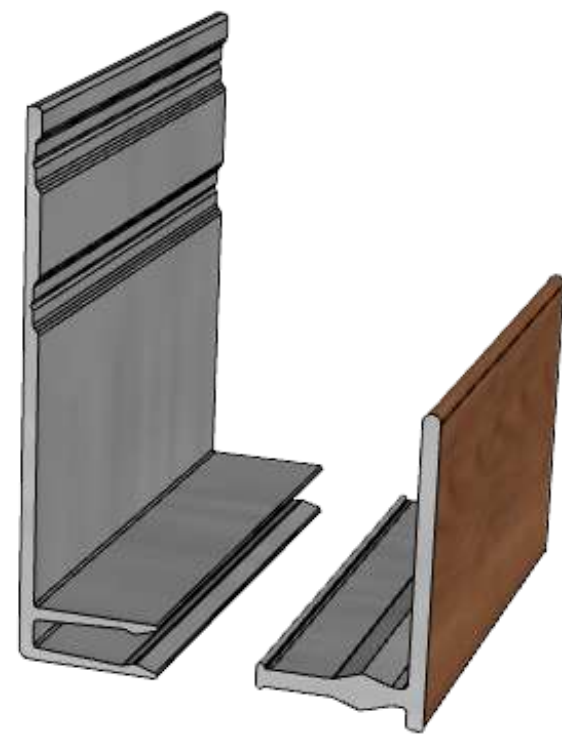

Hard fastening LUXYCLAD® 1" precision J-Trim Base and 1" precision Starter Strip with rain screen clips every 16" on center for proper ventilation. Add an additional screw next to each clip to support the load of cladding.

Note: For a seamless transition, it may be necessary to overlap the 1" precision Starter Strip into the 1" precision J-Trim base. Ensure the pieces are seated flush before final fastening to maintain the 1" precision alignment across the elevation.

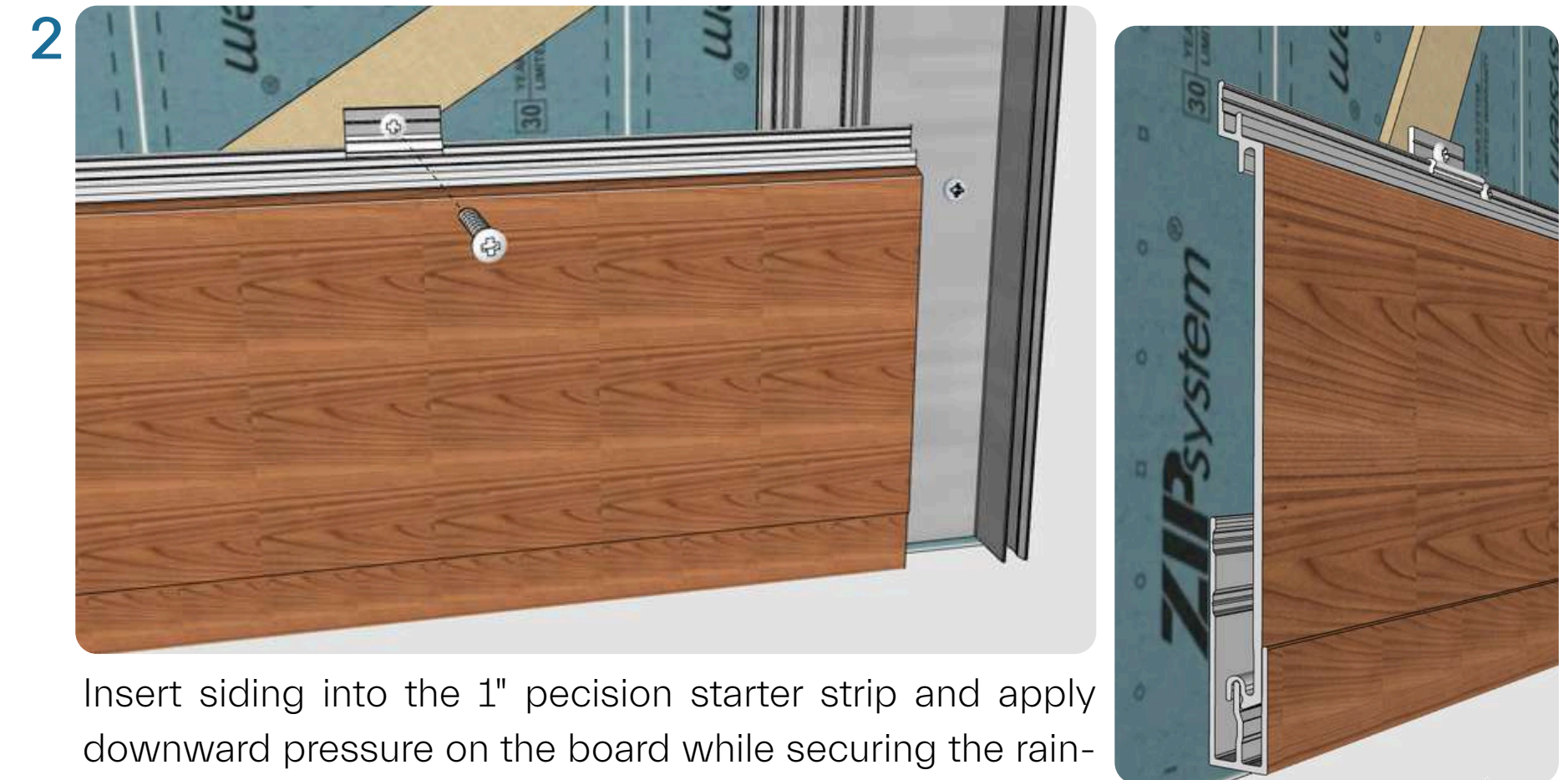

Insert siding into the 1" precision starter strip and apply downward pressure on the board while securing the rain-screen clip, and then fasten the board with the rain-screen clip and screw.

Continue with all the siding until completed.



Apply the final 1" precision J-Trim cap. Be sure to use a tool that will not damage the finish, when driving the 1" precision J-Trim cap into the 1" precision J-Trim base.

1" PRECISION J-TRIM

The LUXYCLAD® 1" Precision J-Trim is used as a sleek, finished border around windows of the cladding system.

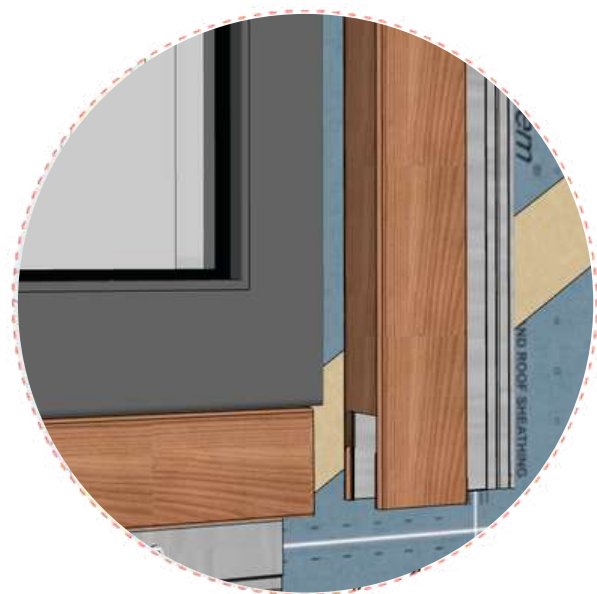
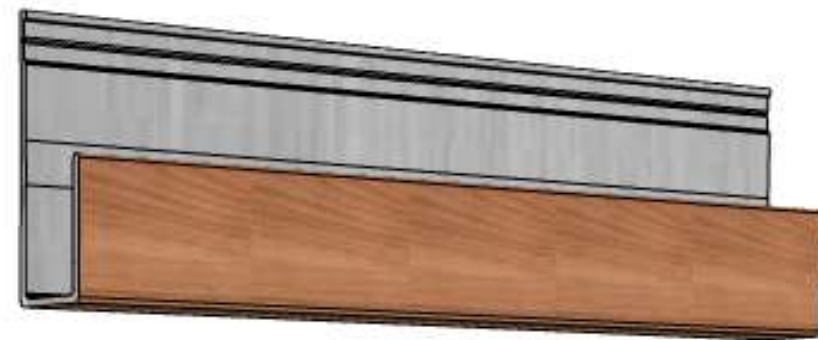

Cut out on the Trim



Hard fastening the LUXYCLAD® 1" precision J-Trims with #8 Pan Head Screws.

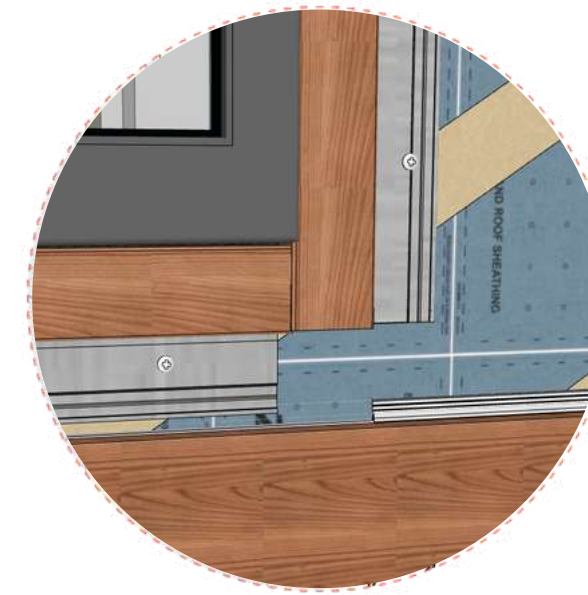

Note: Top support of first siding board must be cut to rest inside the 1" precision J-trim.

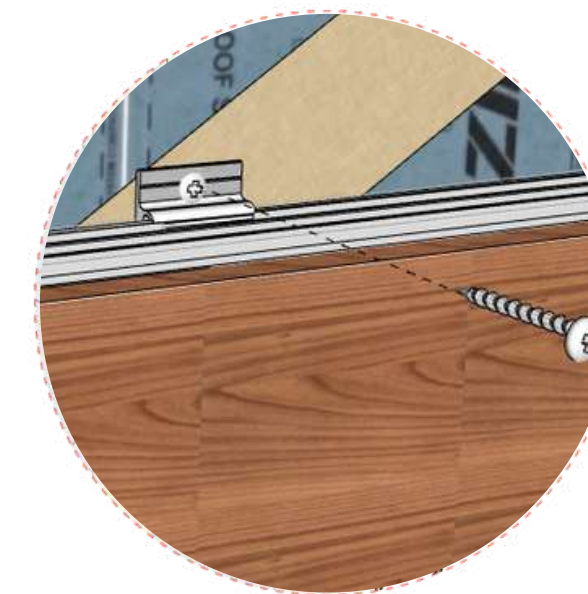

Secure the rain- screen clip, and then fasten the board with the rain-screen clip and screw.



Continue with all the siding until completed.

1" PRECISION OUTSIDE CORNER + BASE

This two-piece system consists of a structural aluminum base and a snap-on finish cover. Engineered to integrate seamlessly with our 1" Precision Starter Strips, the base is designed for a clean overlap to ensure water-tight integrity and perfect structural alignment.



Continue with all the siding until completed.

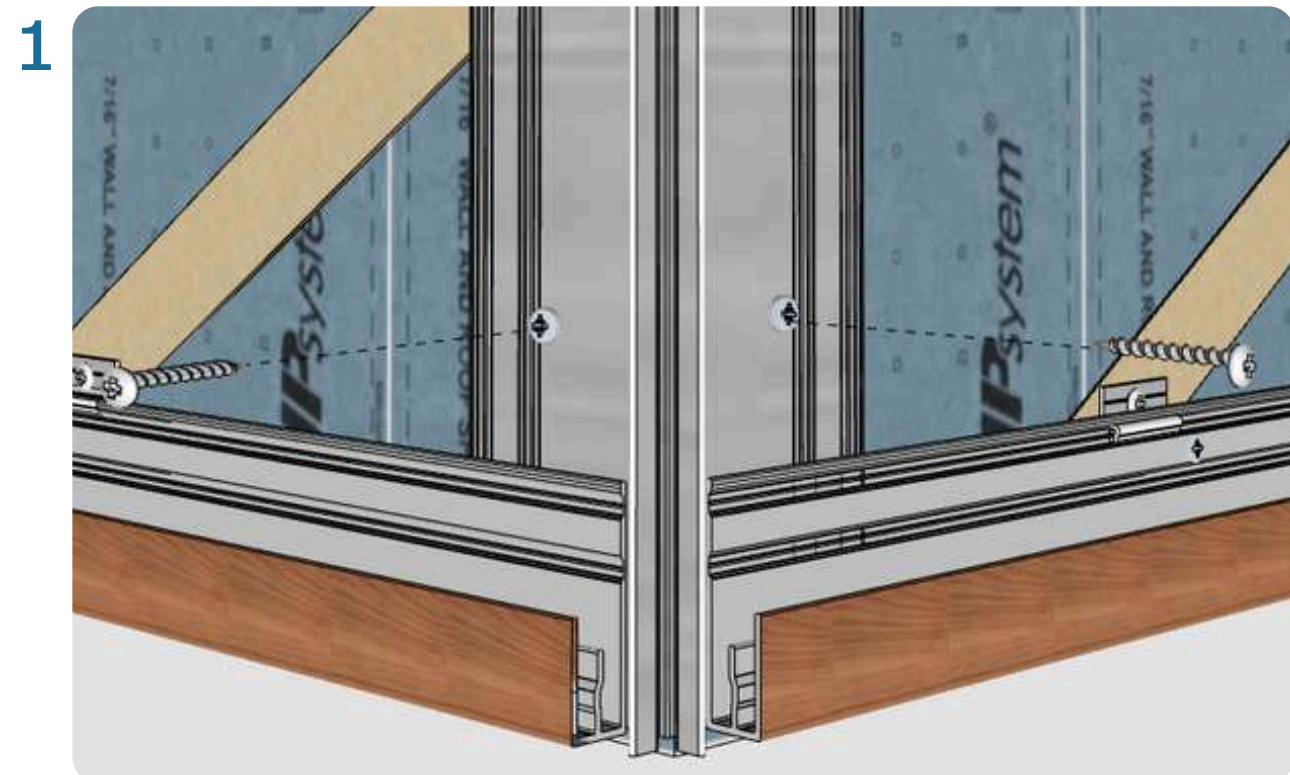

Note: For a seamless transition, it may be necessary to overlap the 1" precision Starter Strip into the 1" precision Outside Corner base. Ensure the pieces are seated flush before final fastening to maintain the 1" precision alignment across the elevation.



Apply the LUXYCLAD® 1" precision Outside corner cap. Be sure to use a tool that will not damage the finish, when driving the 1" precision outside corner cap into the 1" precision outside corner base.

Hard fastening the LUXYCLAD® 1" precision Outside Corner base and two 1" precision Starter Strips with #8 Pan Head Screws.

Add an additional screw next to each clip to support the load of cladding.

- Start by hard fastening the LUXYCLAD® components and component bases: Starter Strips, J-trims, Flat Bases, and Inside/Outside Corner Bases.

Note: Starter strips must be installed with rain screen clips for proper ventilation, and hard fastened to ensure support of siding.

- Insert siding into the starter strip (ensuring that the female portion of the board is sitting in the male portion of the starter strip). Apply downward pressure on the board while securing the rain-screen clip, and then fasten the board with the rain-screen clip and screw.

- Continue with all the siding until completed.

- Once the wall and soffit are completed, hard fasten the finishing base and the final piece of siding. This last piece of siding may need to be ripped - ensure that the final board is tall enough to rest on the finishing strip support.

- Apply the final finishing cap. Be sure to use a tool that will not damage the finish, when driving the finishing cap into the finishing base.

- The stiffness of LUXYCLAD® allows for fastening at 32" O/C (on center). For high wind areas, it is recommended to increase the fastening spacing to 16" O/C (on center).

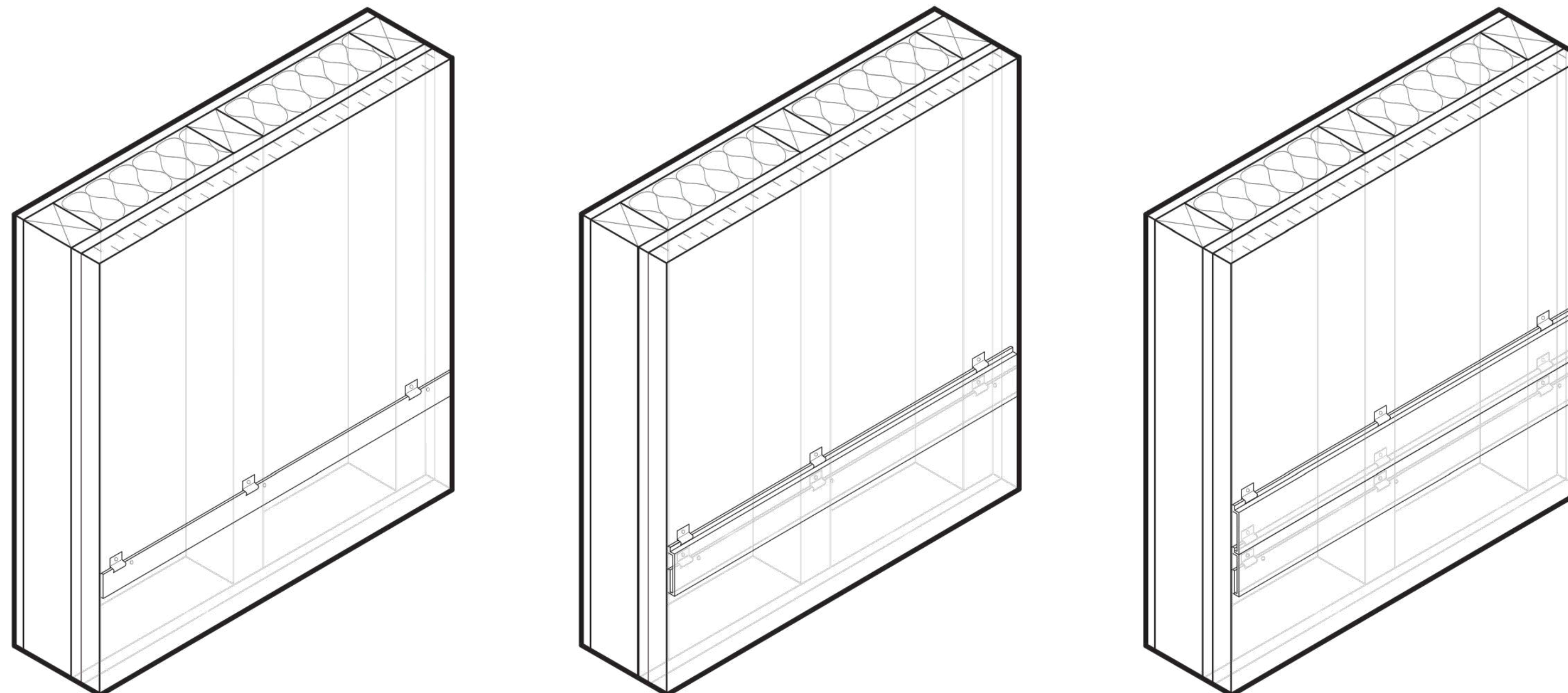

PLAN VIEW: WALL AT WINDOW WITH EXT. INSUL'N + HORIZONTAL SIDING

NOTE: Both starter strips + rain screen clips are to be hard fastened to wall. Horizontal siding installation begins with 1 starter strip at bottom of wall with siding continuing upward. Rain screen clips are recommended to be installed every 32" o/c. In high wind areas, rain screen clips are recommended to be installed every 16" o/c. Diagonal furring strips fastened to wall studs are recommended to allow for ventilation and structural stability, as well as flexibility in allowing siding installation in any direction.

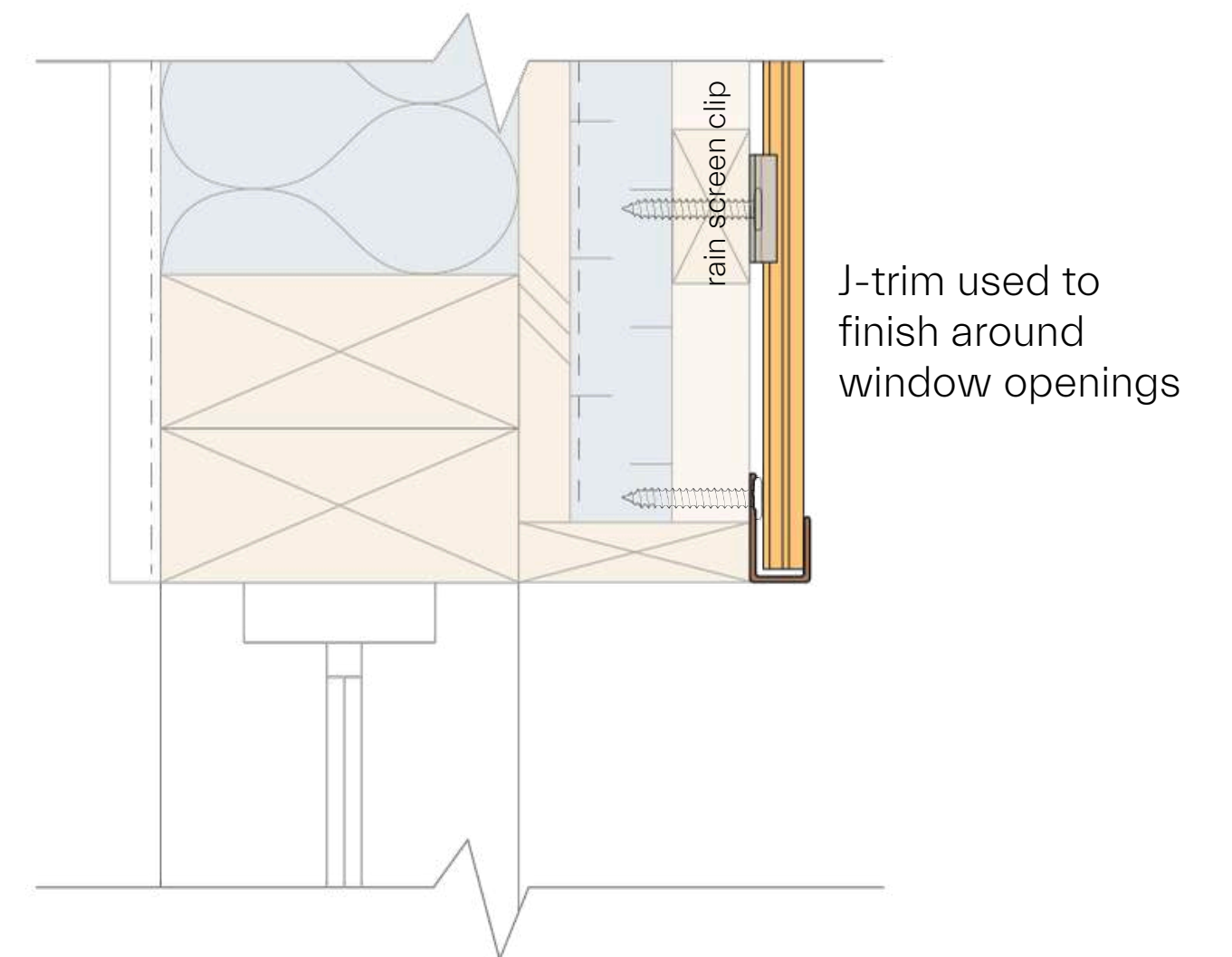
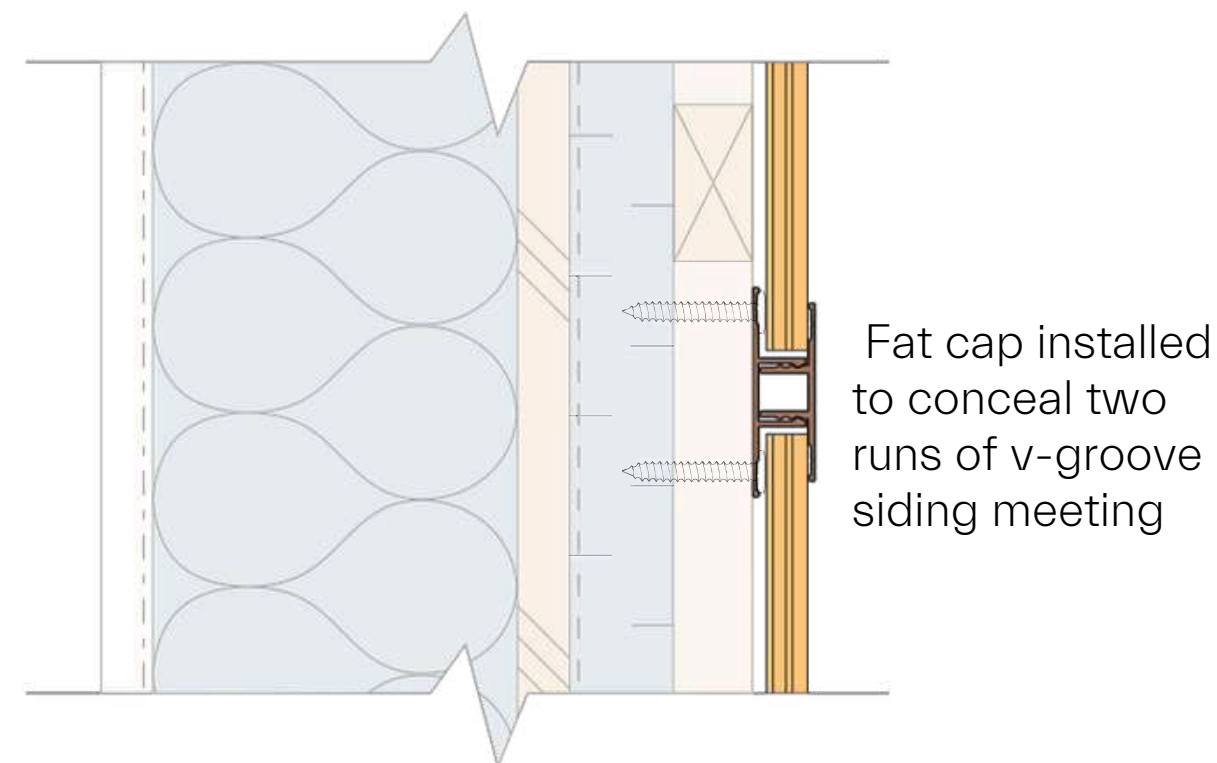
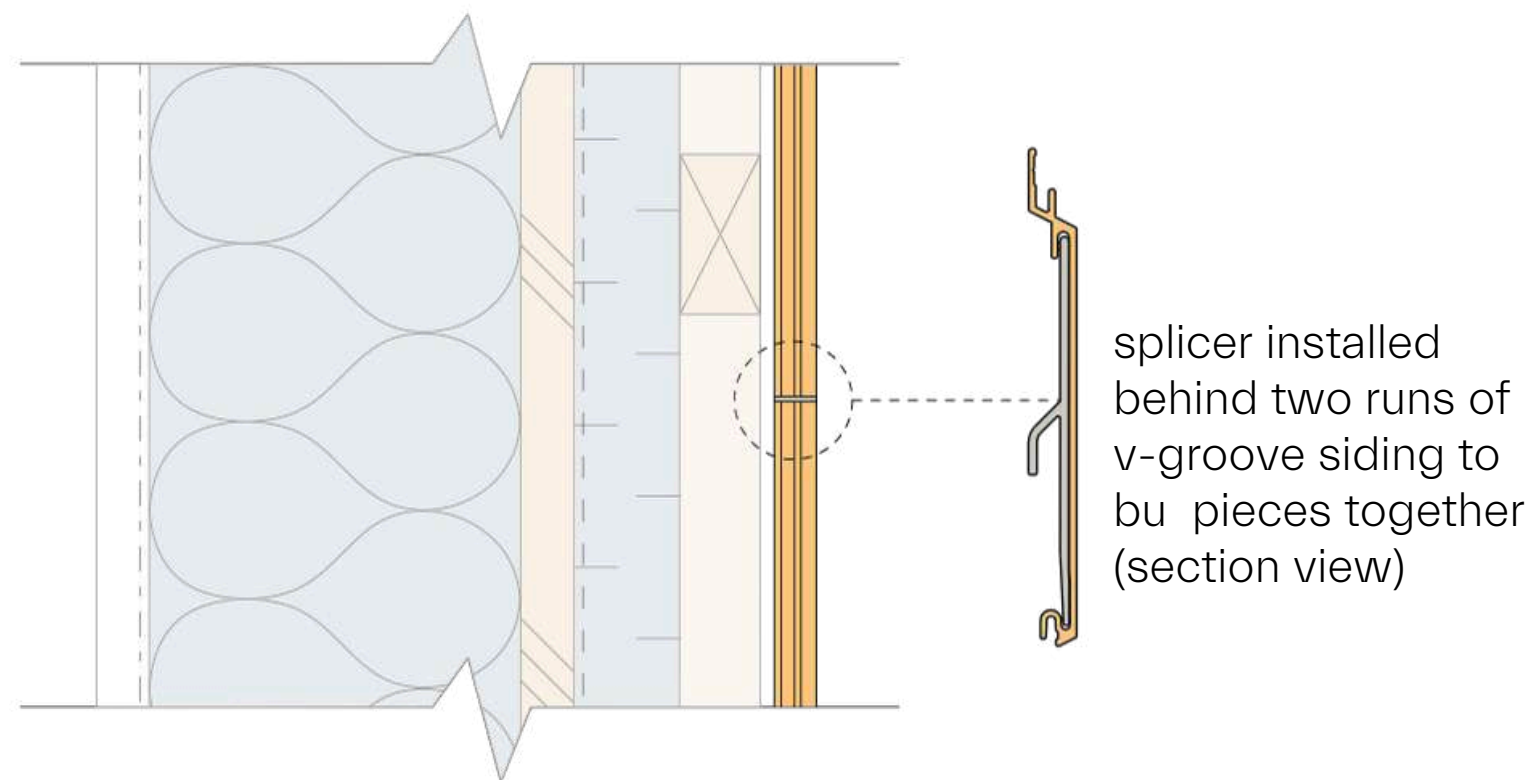

WALL ASSEMBLY: drywall vapour barrier 2x6 stud wall with batt insulation exterior plywood sheathing air barrier exterior rigid insulation furring strips (diagonal recommended) rain screen clips cladding system

PLAN VIEW: WALL AT WINDOW HORIZONTAL SIDING

NOTE: Both starter strips + rain screen clips are to be hard fastened to wall.
Horizontal siding installation begins with 1 starter strip at bottom of wall with siding continuing upward. Rain screen clips are recommended to be installed every 32" o/c. In high wind areas, rain screen clips are recommended to be installed every 16" o/c.

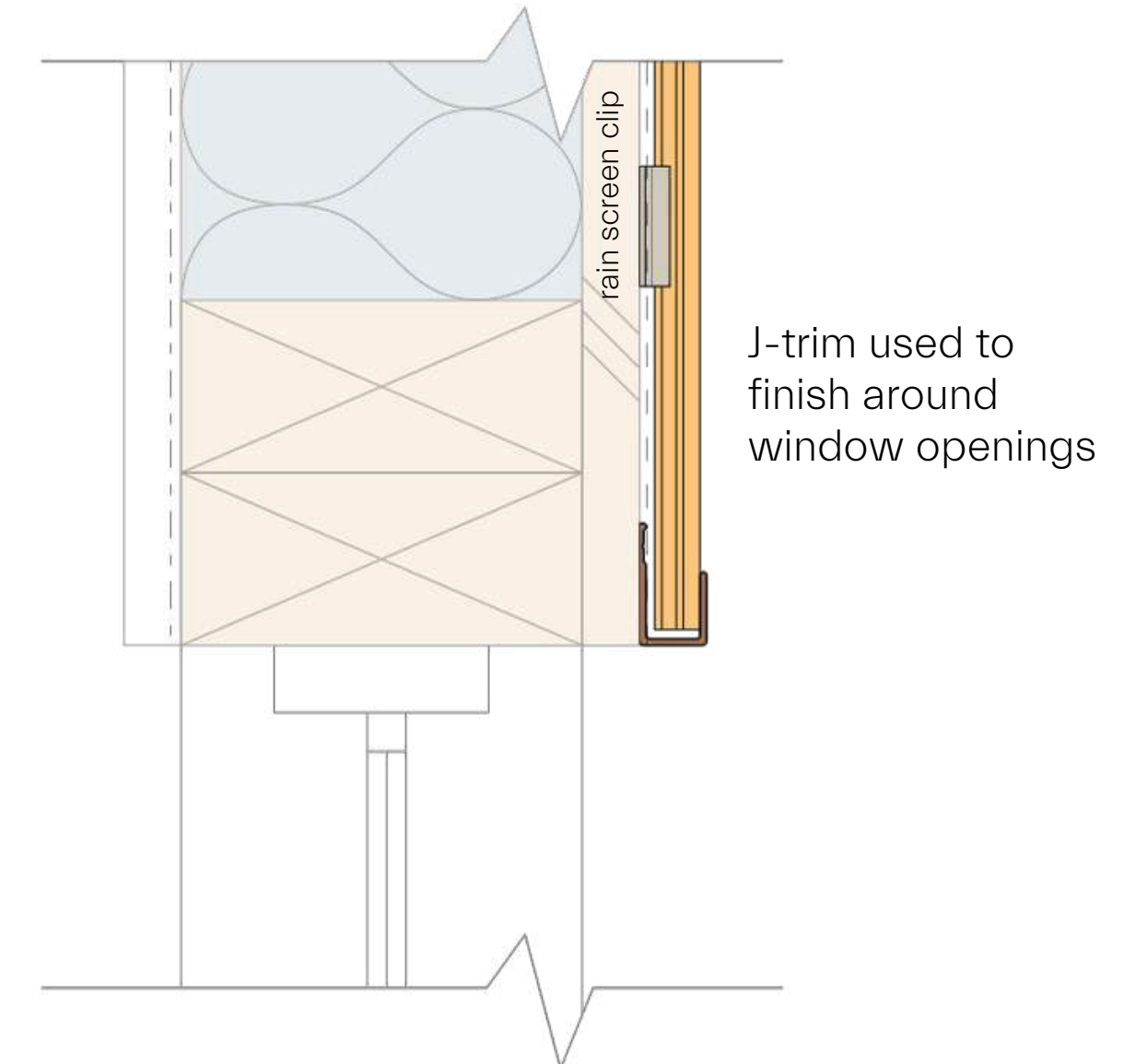
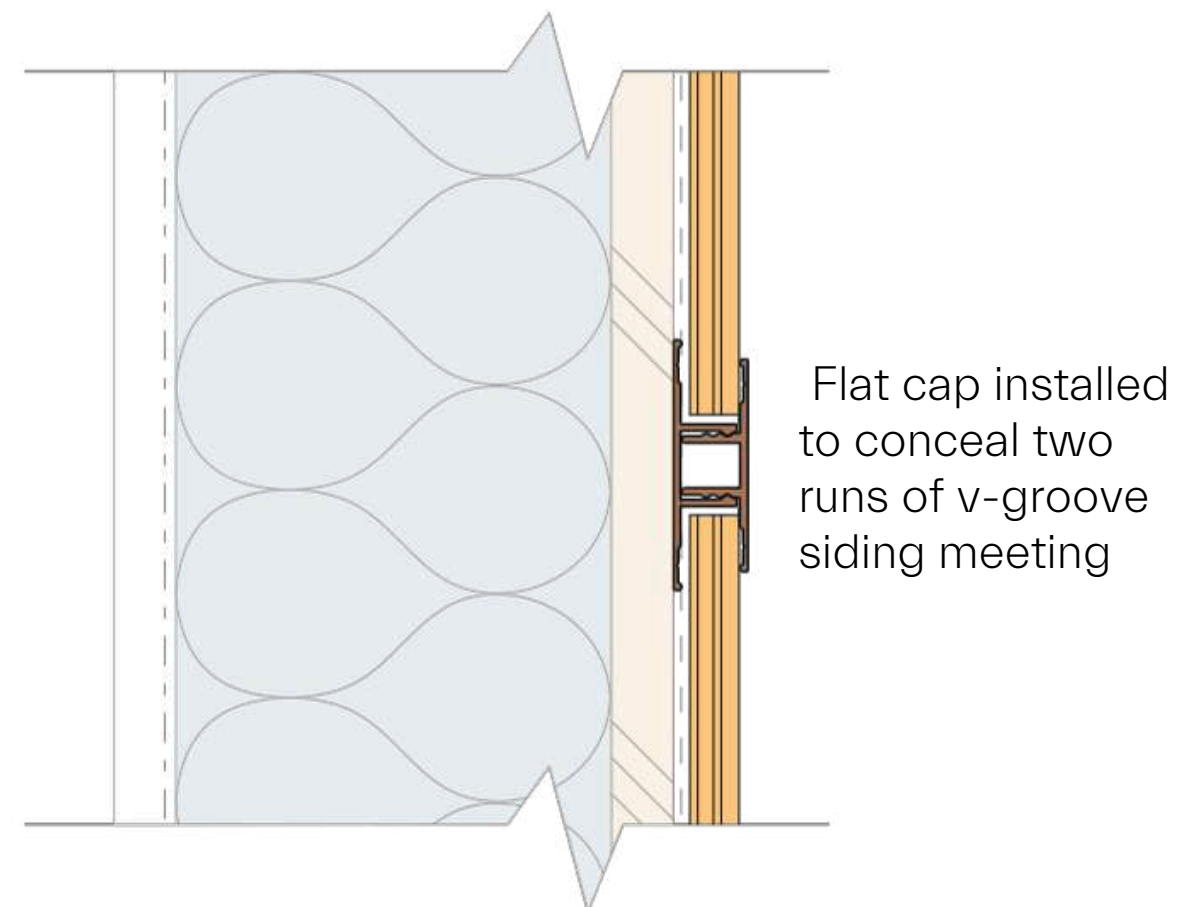
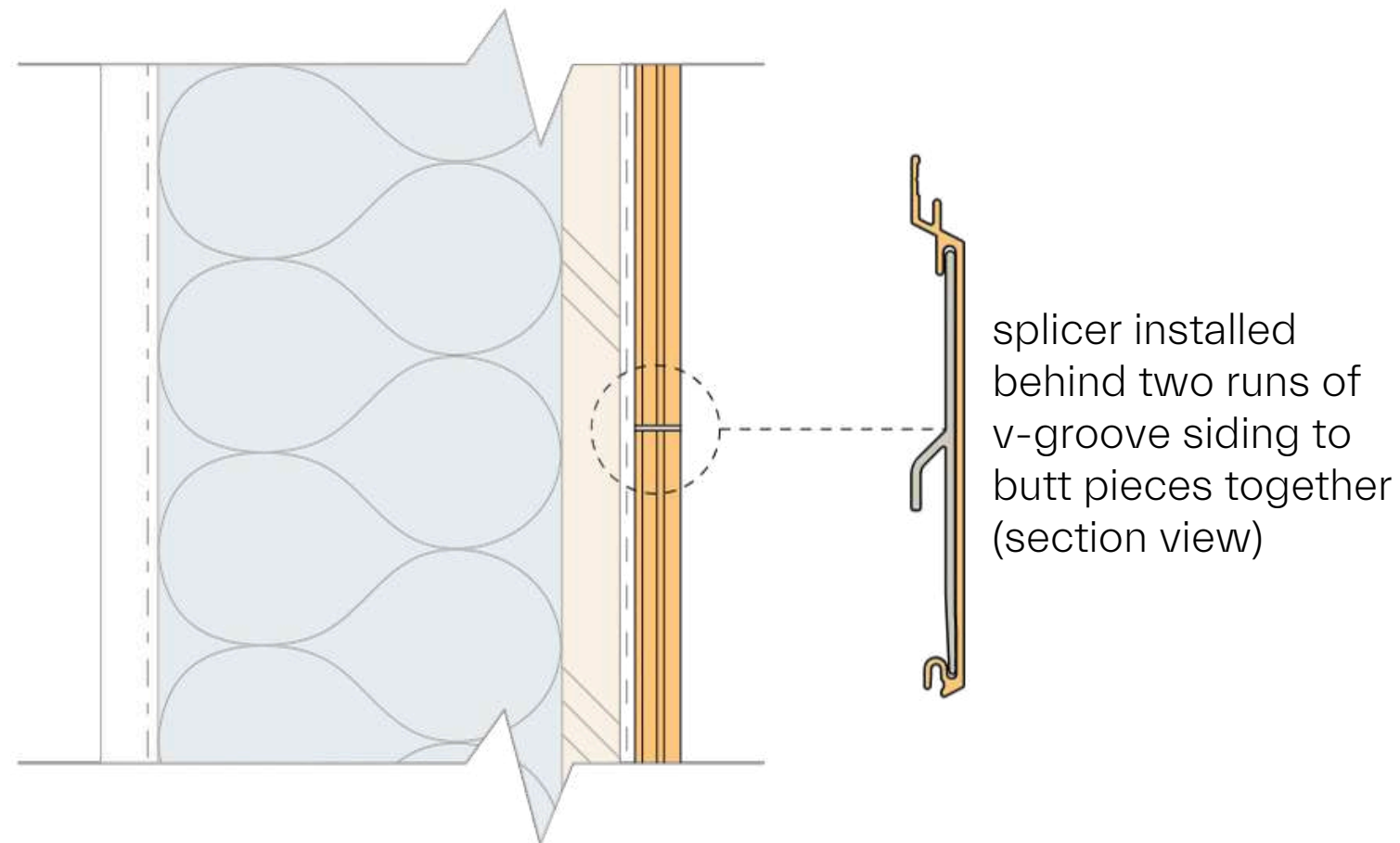

WALL ASSEMBLY: drywall vapour barrier 2x6 stud wall w/ ba insul'n ext. plywood sheathing air barrier rain screen clips cladding system

- **Vertical direction of siding has a similar installation method to horizontal applications, except this assembly starts in the middle of the wall and is built outward in either direction.**
- Start by hard fastening the LUXYCLAD® components and component bases: Starter Strips, J-trims, Flat Bases, and Inside/Outside Corner Bases.
Note: Starter strips must be installed with rain screen clips for proper ventilation, and hard fastened to ensure support of siding.
- Insert siding into the starter strip (ensuring that the female portion of the board is sitting in the male portion of the starter strip). Apply downward pressure on the board while securing the rain-screen clip, and then fasten the board with the rain-screen clip and screw.

- Continue with all the siding until completed.
- Once the wall and soffit are completed, hard fasten the finishing base and the final piece of siding. This last piece of siding may need to be ripped - ensure that the final board is wide enough to rest on the finishing strip support.
- Apply the final finishing cap. Be sure to use a tool that will not damage the finish, when driving the finishing cap into the finishing base.
- The stiffness of LUXYCLAD® allows for fastening at 32" O/C (on center). For high wind areas, it is recommended to increase the fastening spacing to 16" O/C (on center). Diagonal or horizontal strapping/furring strips are recommended to establish a base to adhere vertical siding to.

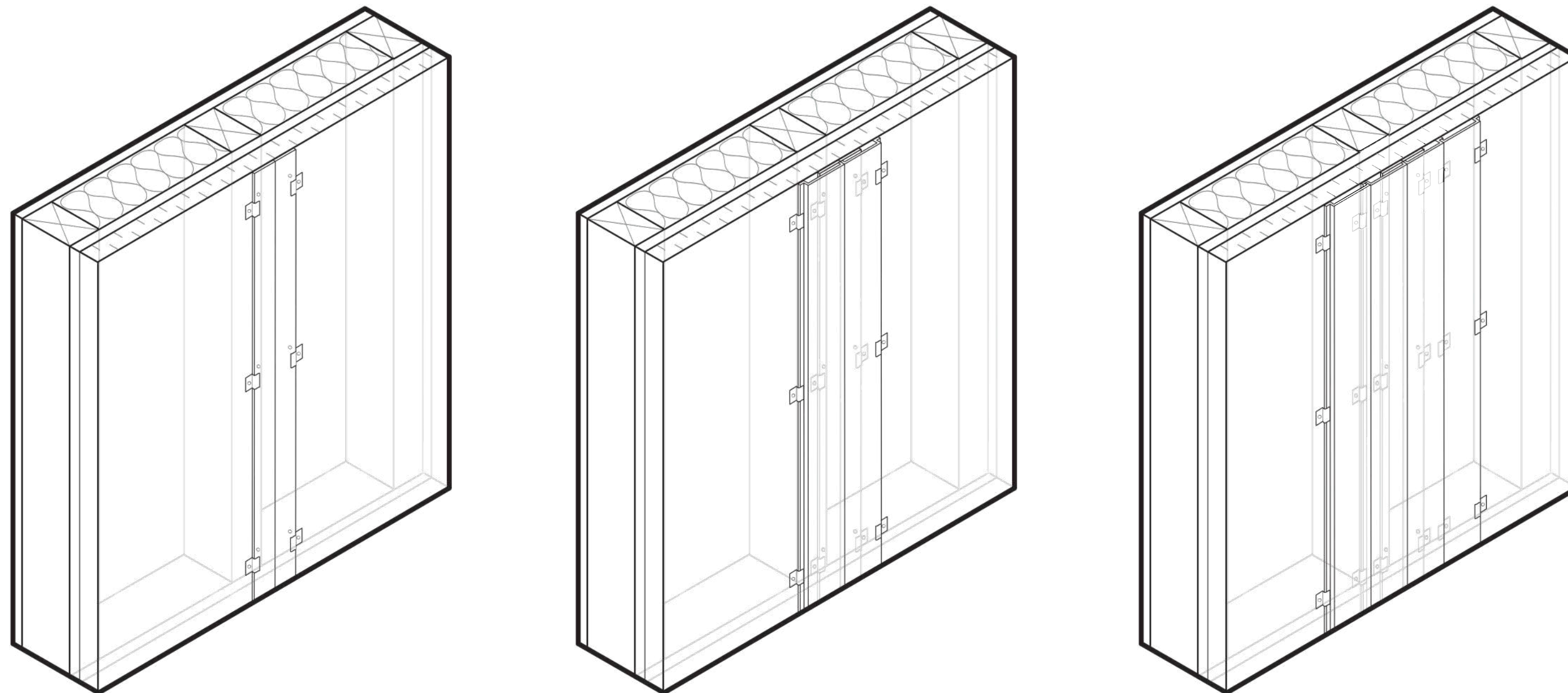

Plan view: WALL AT CORNER WITH EXT. INSUL'N + VERTICAL SIDING

NOTE: Both starter strips + rain screen clips are to be hard fastened to wall.

Vertical siding installation begins with 2 starter strips back to back at centre of wall with siding continuing outward in both directions. Rain screen clips are recommended to be installed every 32" o/c. In high wind areas, rain screen clips are recommended to be installed every 16" o/c. Diagonal furring strips fastened to wall studs are recommended to allow for ventilation and structural stability, as well as flexibility in allowing siding installation in any direction. Pieces of siding entering finishing strips are to be ripped along the top to allow for proper insertion into trim piece.

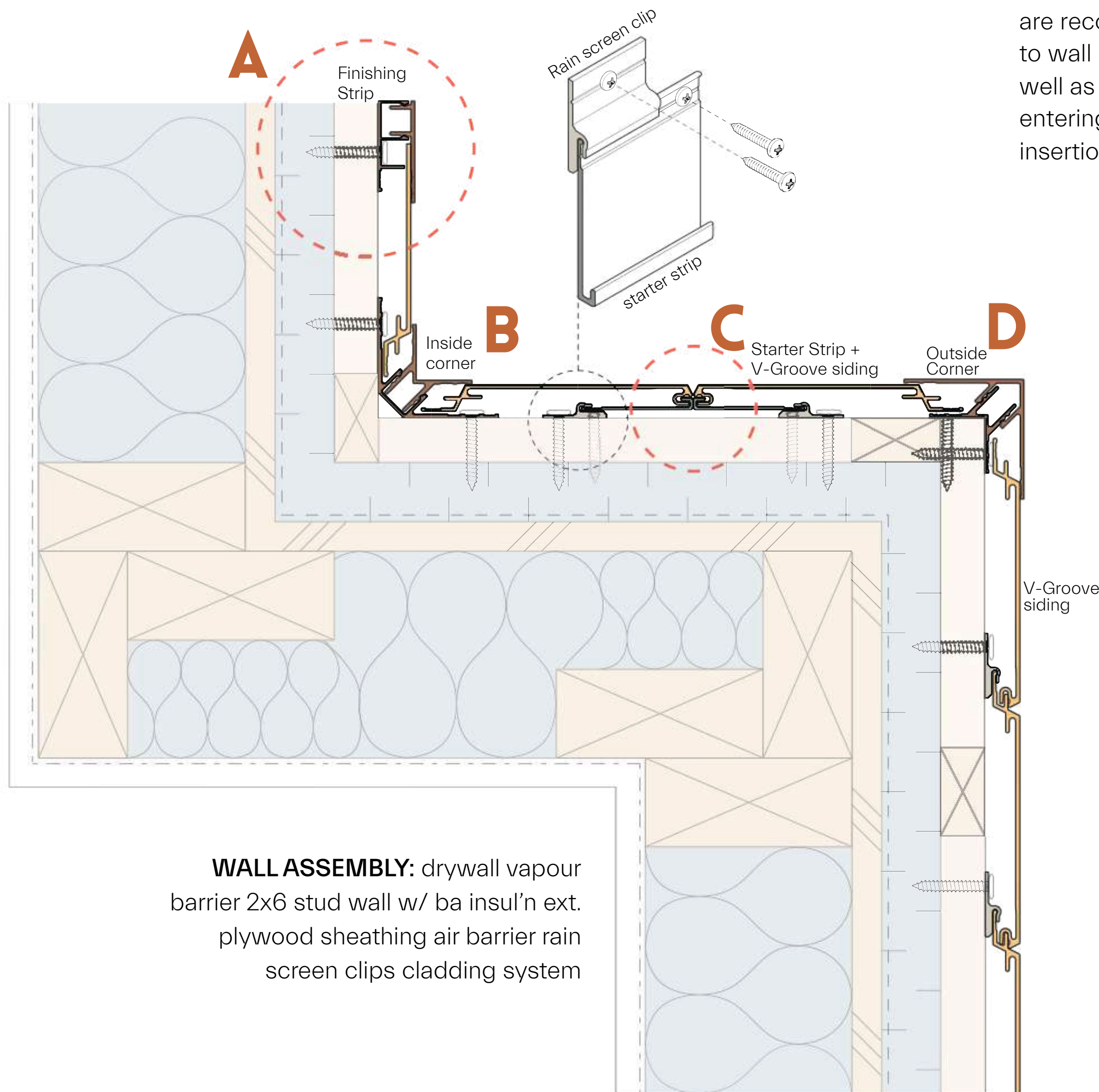

WALL ASSEMBLY: drywall vapour barrier 2x6 stud wall w/ ba insul'n ext. plywood sheathing air barrier rain screen clips cladding system

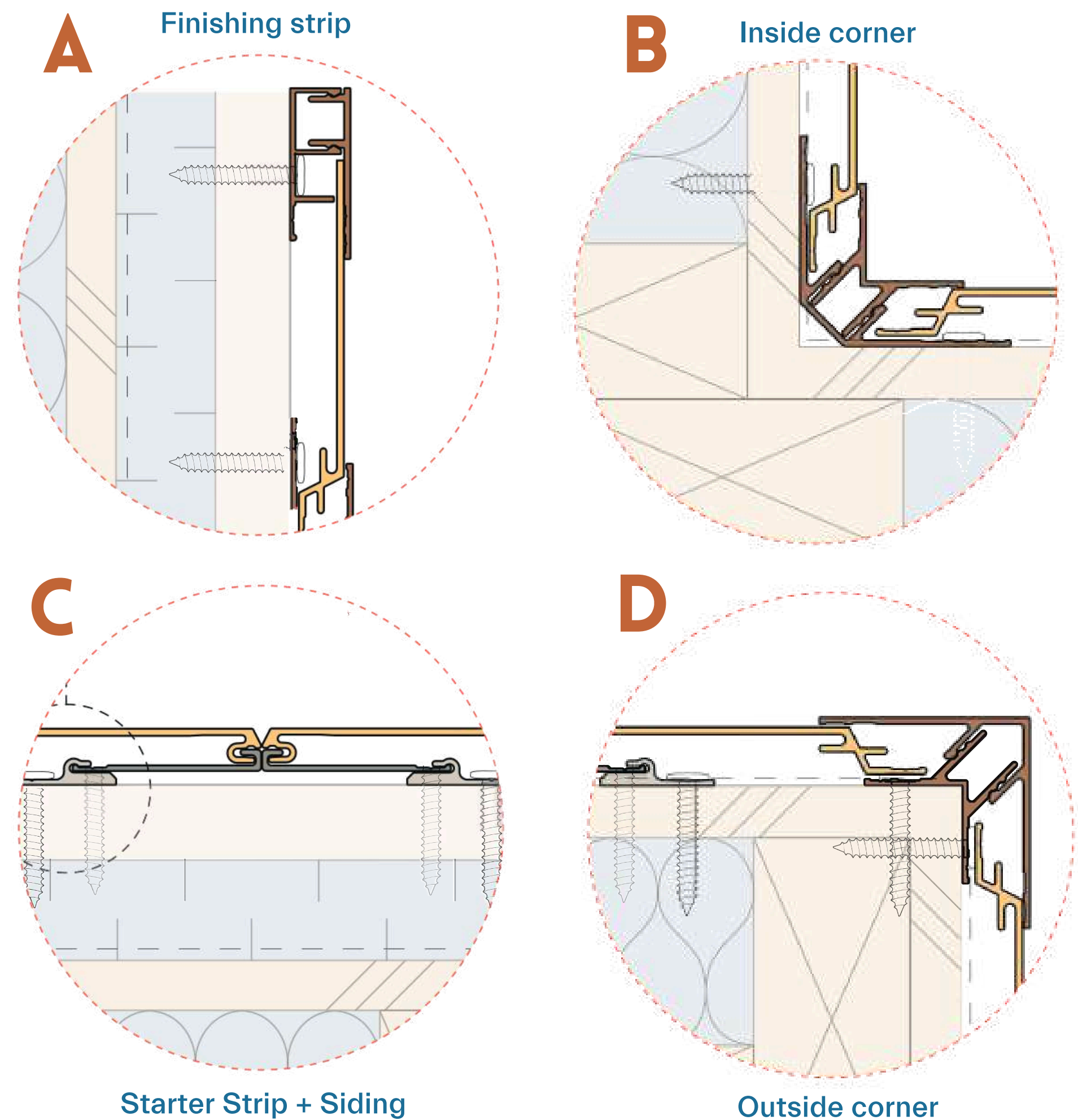

Starter Strip + Siding

Outside corner

- Install all starter strips, J trims, and corner pieces before installing LUXYCLAD[®] cladding profiles. On very short runs, using a more precise cut may be necessary, as the profile cannot be flexed into the area between two trim pieces.
- Press the starter strip against the fascia.
- Insert the soffit (female profile) onto the male starter strip, and fasten with a clip and screw.
- Insert the integrated venting strip (female profile) onto the male soffit profile, and fasten with clip and screw. **Note: Some applications benefit from applying black building paper to the framing material above the vent area to reduce the visibility of framing lumber through the vent.**
- Continue with the soffit until completed.
- The final soffit piece may need to be ripped. Use the finishing strip snap component to finish the run.
- The LUXYCLAD[®] perforated vent provides 84" of NVA (Net Ventilated Area) per 12' stock length. Ensure adequate venting is used as per code requirements. **Note: 21 lineal ft. = 1 sqft. of Net Vent Area perpendicular to house soffit installation.**
- Center two starting strips between fascias and fasten through the flange.
- Insert the soffit (female profile) onto the male starter strip, and fasten through the flange.
- Build outward towards fascia corners.
- Install adequate amount of integrated venting strips to meet local building codes.

Section view: WALL AT SOFFIT WITH EXT. INSUL'N + GABLE ROOF

NOTE: Both starter strips + rain screen clips are to be hard fastened to wall. Horizontal siding installation begins with 1 starter strip at bottom of wall with siding continuing upward. Rain screen clips are recommended to be installed every 32" o/c. In high wind areas, rain screen clips are recommended to be installed every 16" o/c. Diagonal furring strips fastened to wall studs are recommended to allow for ventilation and structural stability, as well as flexibility in allowing siding installation in any direction. Pieces of siding entering nishing strips are to be ripped along the top to allow for proper insertion into trim piece.

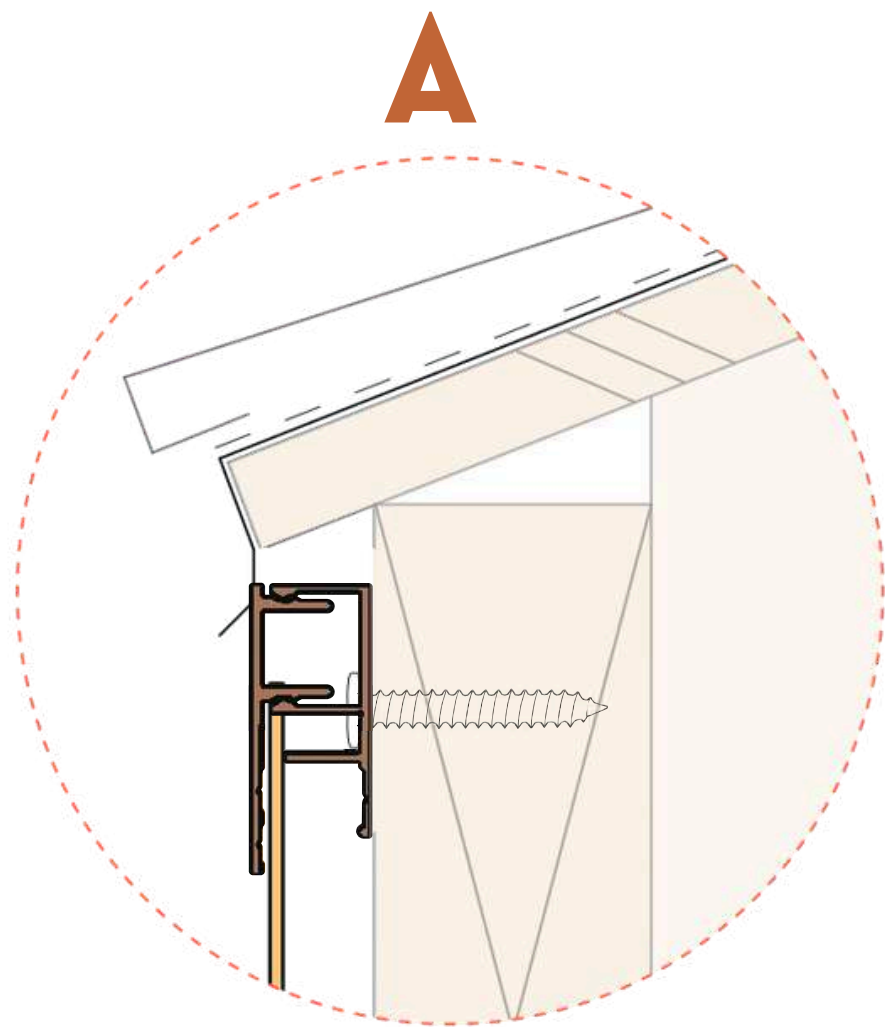

Finishing strip at top of fascia

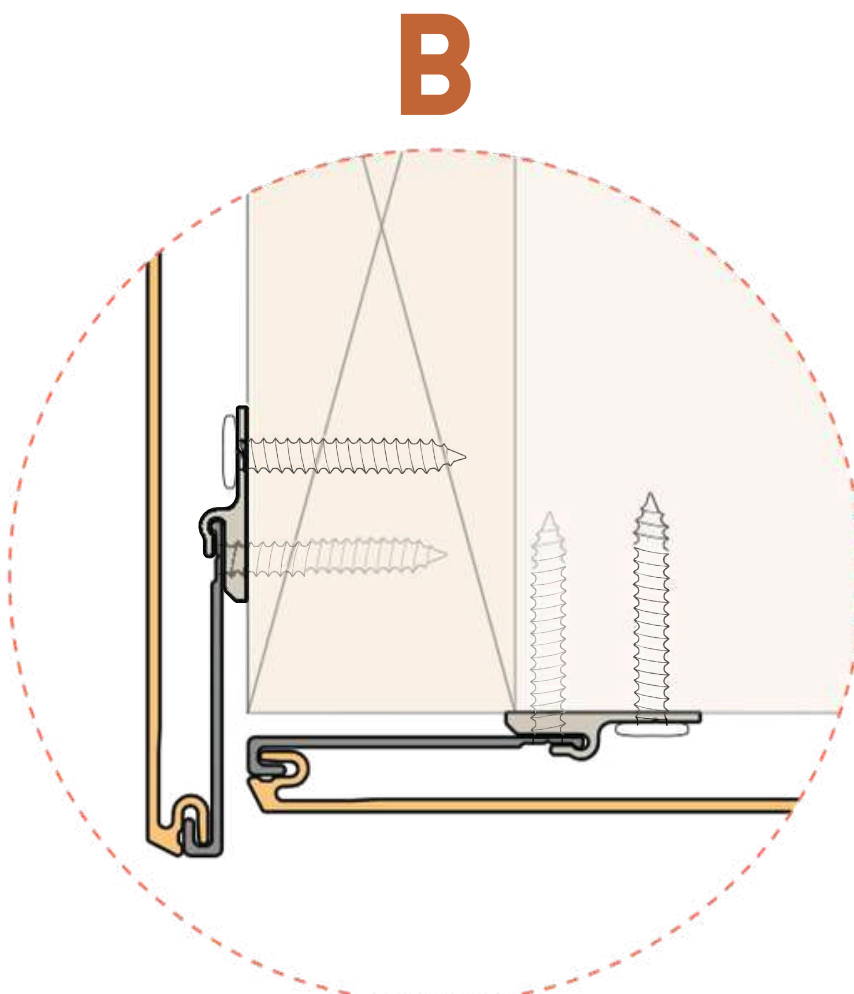

Drip edge created by starter strips + siding

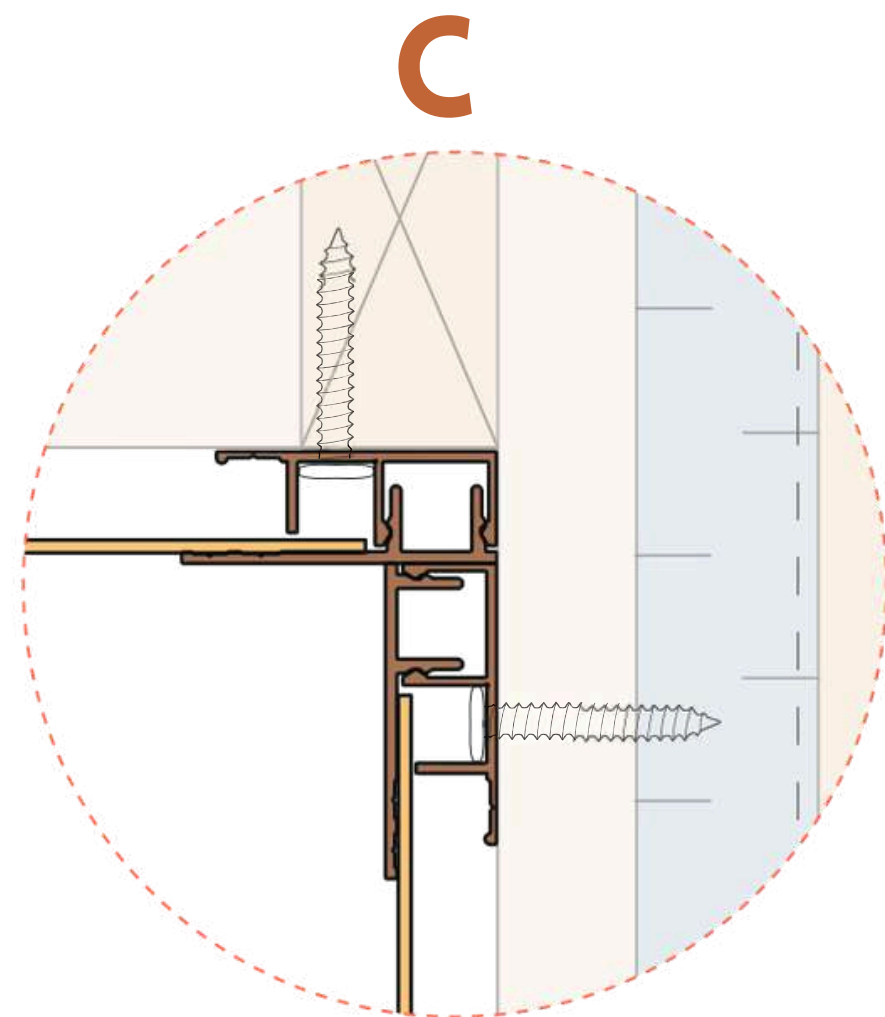

Back to back finishing strips used in soffit to wall corner transition

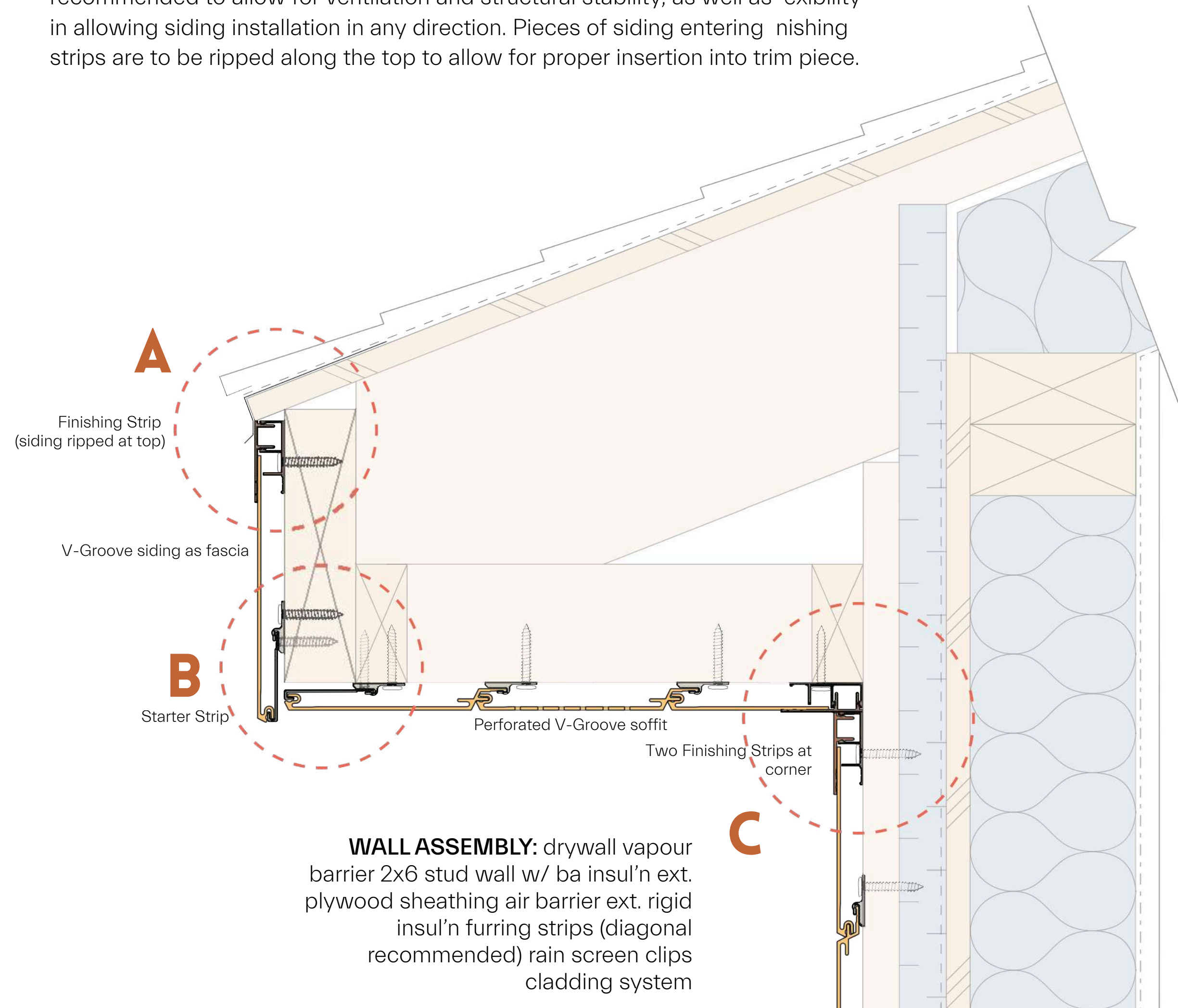

WALL ASSEMBLY: drywall vapour barrier 2x6 stud wall w/ ba insul'n ext. plywood sheathing air barrier ext. rigid insul'n furring strips (diagonal recommended) rain screen clips cladding system

Section view: WALL AT SOFFIT FLAT ROOF

NOTE: Both starter strips + rain screen clips are to be hard fastened to wall. Horizontal siding installation begins with 1 starter strip at bottom of wall with siding continuing upward. Rain screen clips are recommended to be installed every 32" o/c. In high wind areas, rain screen clips are recommended to be installed every 16" o/c. Pieces of siding entering nishing strips are to be ripped along the top to allow for proper insertion into trim piece.

D

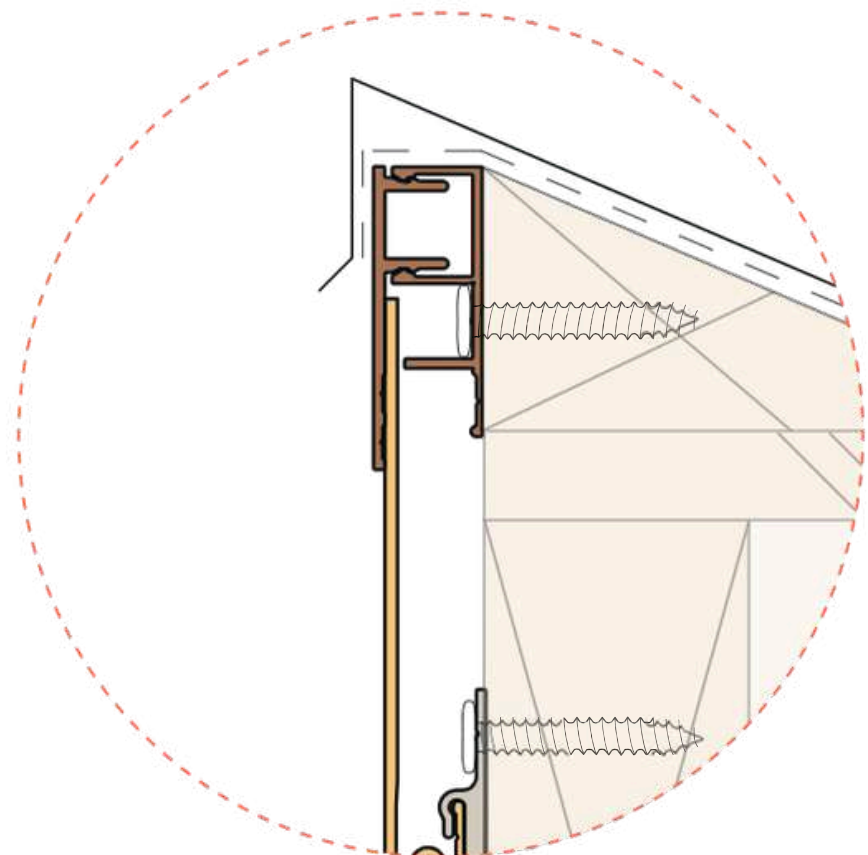

Finishing strip at top of fascia

E

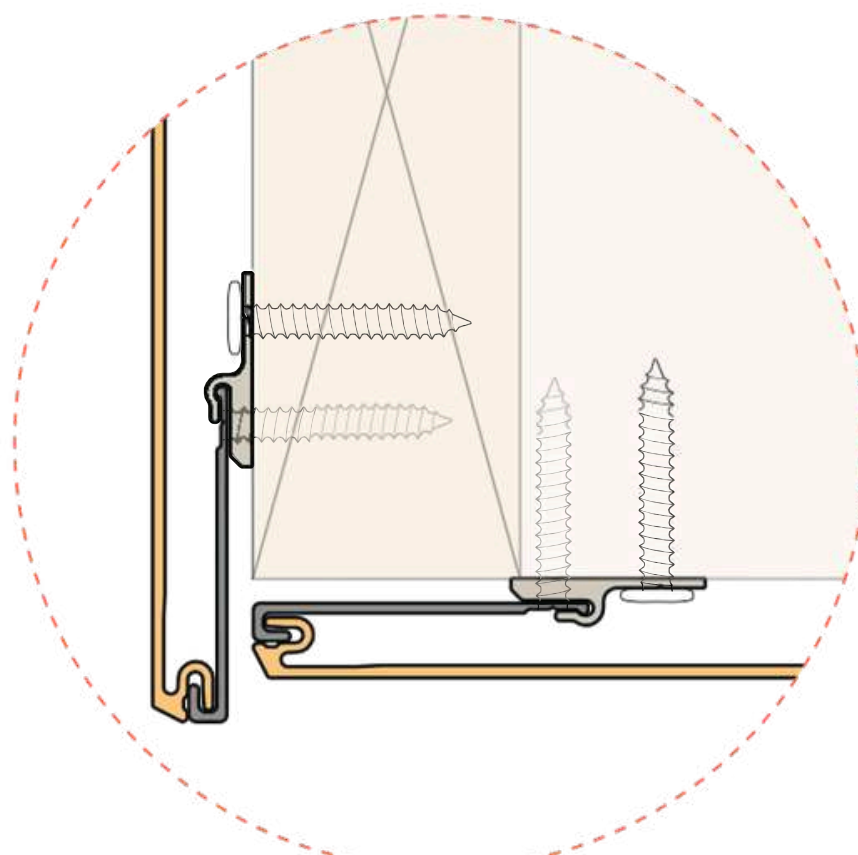

Drip edge created by starter strips + siding

F

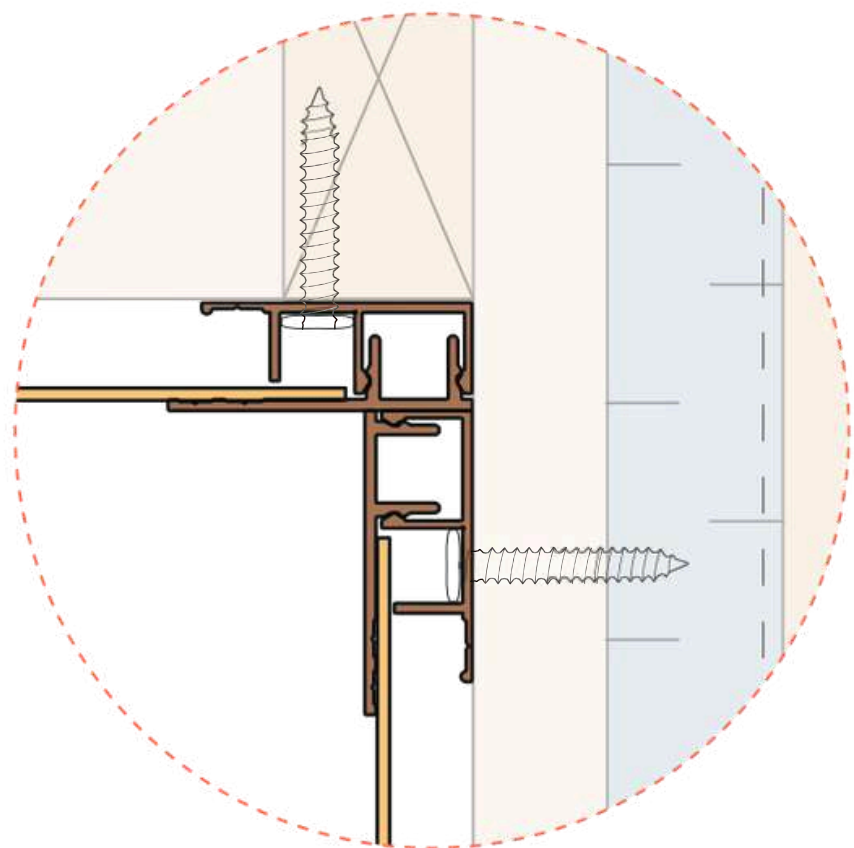

Inside corner used for soffit to wall corner transition

D

Finishing Strip (siding ripped at top)

V-Groove siding as fascia

E

Starter Strip

Perforated v-groove soffit

Inside Corner

F

WALL ASSEMBLY: drywall
vapour barrier 2x6 stud wall w/
ba insul'n ext. plywood
sheathing air barrier rain screen
clips cladding system

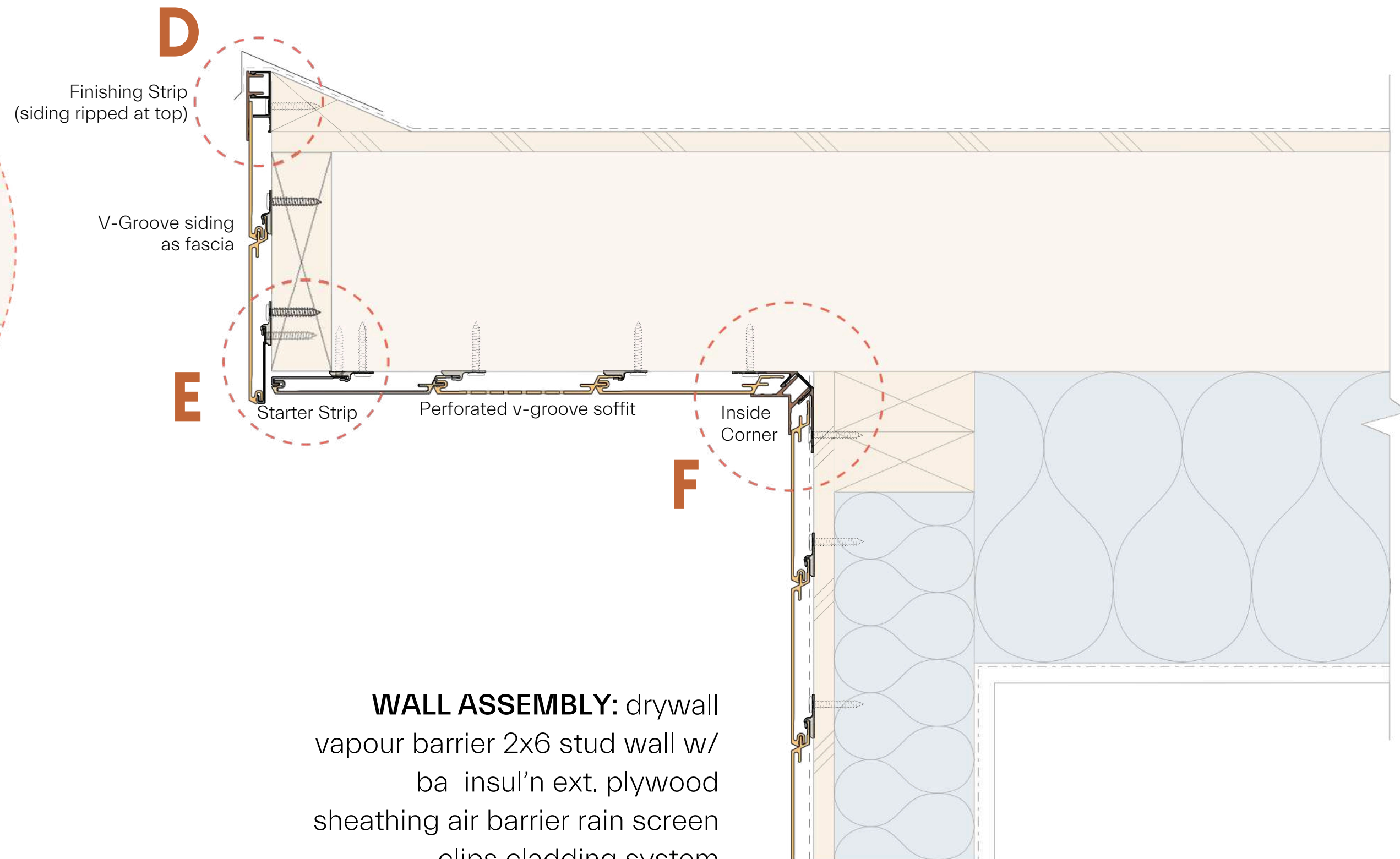

LUXYCLAD[®] Aluminum
Architectural
Systems

THANK YOU

FOR MORE PRODUCT INFORMATION
VISIT OUR WEBSITE



76 RIDLEY ROAD
ST CATHARINES ON L2S 3Y8



1 (877)-255-1022
info@luxyclad.com