

WWW.LUXYCLAD.COM

 **LUXYCLAD**[®] Aluminum
Architectural
Systems

HIGH PERFORMANCE SIDING & SOFFIT SYSTEM





CONTENTS

AboutUs	ADVANCED SIDING & SOFFIT SYSTEM	01
How It's Made	INNOVATIVE ARCHITECTURAL SOLUTIONS	02
Our Products	HIGH-PERFORMANCE SIDING AND SOFFIT SYSTEMS	03
Snap-in Batten	A NEW COMPLETE AND VERSATILE SYSTEM	04
Profiles & Trims	A COMPLETE RAIN SCREEN CLADDING SYSTEM	05
Performance	ADDITIONAL FEATURES & BENEFITS OF LUXYCLAD	06
Sustainability	SUSTAINABLE COMMITMENT	08
Finishes	WIDE RANGE OF WOOD ALTERNATIVE FINISHES	09

WELCOME TO THE FUTURE OF SIDING

LUXYCLAD® is a premier Canadian manufacturer committed to delivering high-quality building solutions across North America. Offering a low-maintenance alternative to traditional wood siding,

LUXYCLAD® provides a complete system of seamless extruded aluminum planks with precisely engineered mechanical anchoring components. Each product features a hyper-durable powder-coated finish applied to premium aluminum substrates, ensuring long-lasting protection, rich color depth, and enduring architectural appeal.

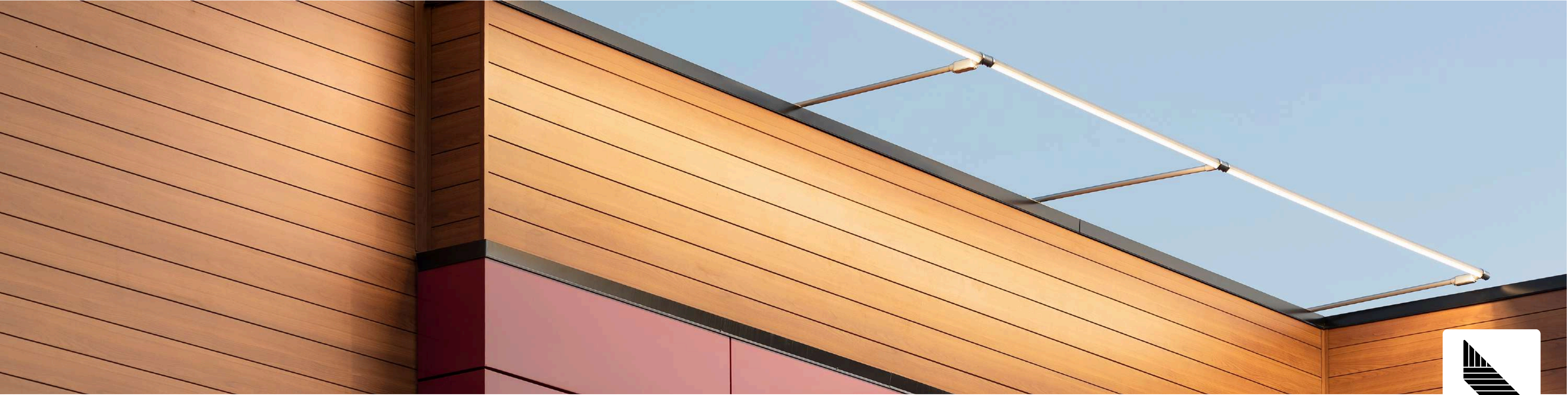

ABOUT US

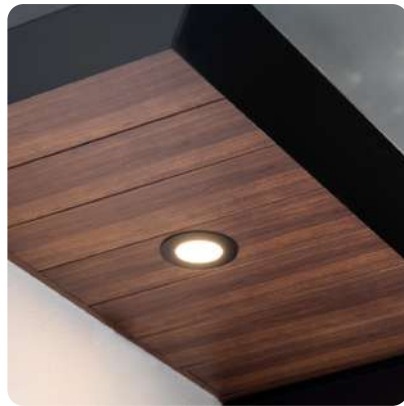

At LUXYCLAD®, we specialize in designing and producing architectural-grade cladding systems crafted from carefully selected materials and enhanced with the latest finishing technologies to achieve exceptional durability and visual appeal. Our products combine hyper-durable powder coatings with premium aluminum substrates, ensuring long-lasting protection and vibrant, enduring finishes.

For added realism and warmth, our wood-grain surfaces are enhanced with UV-stable inks through advanced sublimation processes, creating true-to-life textures that beautifully withstand time and the elements. Driven by innovation, craftsmanship, and sustainability, LUXYCLAD® empowers architects, builders, and designers to bring their visions to life – creating structures that are inspiring, durable, and environmentally responsible.

Advanced Siding & Soffit System



LUXYCLAD® is a high-performance siding & soffit system which utilizes hidden, mechanically anchored rain screen clips to allow for rear ventilation and natural movement. The system protects the wall assembly and improves the energy efficiency of a new or existing building.



INNOVATIVE ARCHITECTURAL SOLUTIONS

At LUXYCLAD®, quality and innovation define every step of our manufacturing process. We use advanced extrusion techniques to produce precise, durable profiles engineered for demanding architectural applications.

Our products are finished using hyper-durable powder coatings applied through a state-of-the-art vertical powder coating line, ensuring smooth, consistent, and long-lasting surfaces.

HOW IT'S MADE

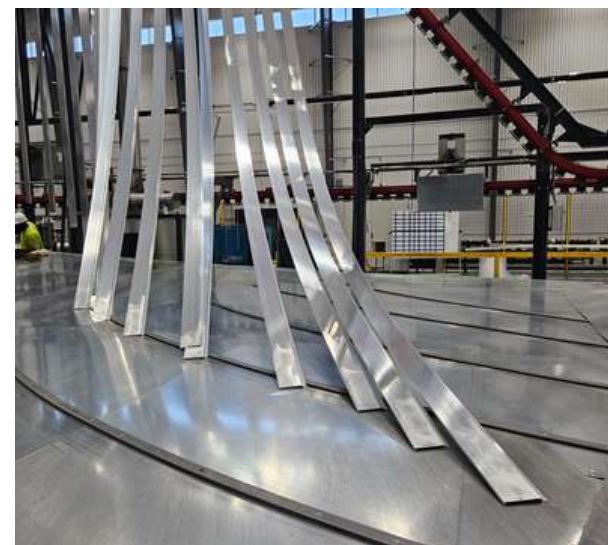

Extruded Aluminum

LUXYCLAD® specializes in high-quality architectural cladding using extruded aluminum, offering lightweight, durable, and corrosion-resistant profiles. This process enables intricate designs with easy installation, ensuring long-lasting, versatile, and visually striking building façades.

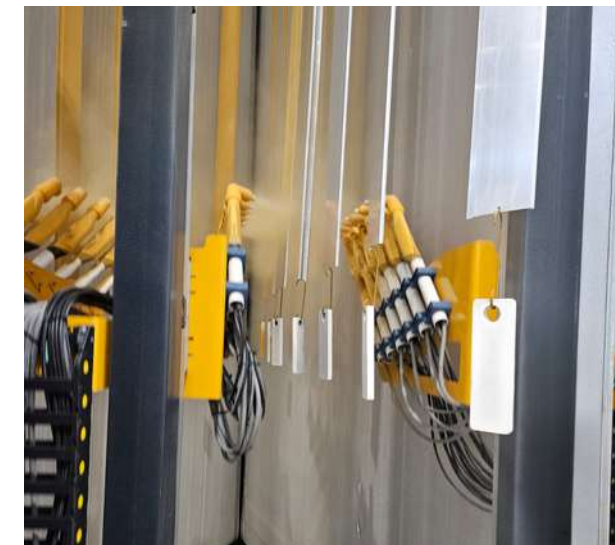

Powder Coating

LUXYCLAD® uses environmentally friendly powder coating technology to achieve flawless, durable finishes. This process provides excellent resistance to impact, moisture, chemicals, and weather, maintaining vibrant colors and reducing the need for maintenance, making it ideal for high-traffic and demanding environments.



Dye Sublimation

LUXYCLAD® uses advanced sublimation technology to create realistic wood-grain finishes by embedding UV-stable inks into powder-coated surfaces. This process ensures enhanced durability and authentic aesthetics, seamlessly blending beauty with resilience.



OUR PRODUCTS

At LUXYCLAD®, we deliver high-performance siding and soffit systems that combine durability, aesthetics, and energy efficiency. Engineered for sustainability and versatility, our products offer a wide range of profiles, finishes, and colors—empowering design freedom while ensuring lasting performance and easy installation.



SIDING

LUXYCLAD® offers a low-maintenance, aluminum siding system with seamless planks and secure anchoring, ideal for commercial and upscale residential façades.

FEATURES

- Exterior or Interior application
- Horizontal, Vertical, or Diagonal installation
- Large format boards: 24' x 4" or 24' x 6"
- Thickness: 2 mm
- Interlocking v-groove design
- Protects against water infiltration
- Suitable for corrosive environments



SOFFIT & FASCIA

LUXYCLAD® offers protection, ventilation, and a seamless finished look from soffit to fascia, enhancing visual appeal while preventing pests, distortion, and staining needs.

FEATURES

- Suitable for both internal and external use
- Safe for high-wind climates
- Will not sag or droop over time
- Impact and dent resistant (3mm thickness)
- Vented soffit profiles available to meet building code requirements
- Low maintenance



SNAP-IN BATTEN & LOUVRE

LUXYCLAD® Battens & Louvre are durable, versatile products suitable for ceilings, fencing, shading, and privacy screens, featuring an easy snap-fit design for simple, impactful installation with striking linear aesthetics.

FEATURES

- Integrated splicing system
- Vertical, horizontal or diagonal orientations
- Hidden fastening system
- 100 mm and 150 mm formats
- Custom lengths available (3,657 -7,315 mm)
- Sustainable (made from 70% recycled material, 100% recyclable)
- No VOCs



SNAP-IN BATTENS

LUXYCLAD®'s Snap-In Battens are light-weight, easy-to-install and manufactured from extruded aluminum, offering a dimensionally stable, long-lasting, non-combustible, and low maintenance alternative to timber. Snap-In Battens are coated using an eco-friendly and hyper durable powder-coated finish, providing superior durability with a photo-realistic finish. Snap-In Battens allow for design flexibility and are suitable for a wide range of applications

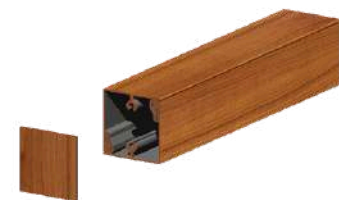

2" X 2" BATTEN
24' LENGTHS



2" X 4" BATTEN
24' LENGTHS



2" X 6" BATTEN
24' LENGTHS

Additional Batten sizes available
Contact us for details

Application & Mechanical Fixing



Snap-In Battens are suitable for use on external walls as an open joint rainscreen siding system and are designed to be installed vertically, horizontally, or on external or internal walls and ceiling as decorative cladding for residential and commercial buildings. Snap-In Battens are comprised of 2 piece snap fit extrusions with matching end-caps, utilizing hidden #12 fasteners to mechanically fasten one piece to the substrate with the second, matching piece snapping in to complete the pair.

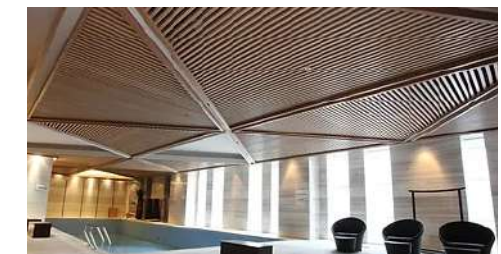

A Complete Rain Screen Cladding System

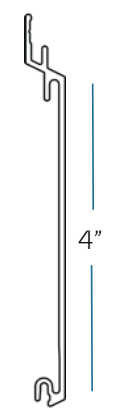
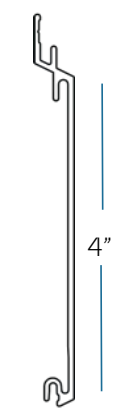
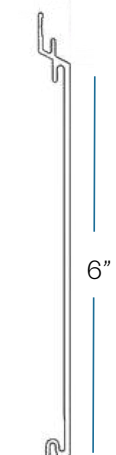
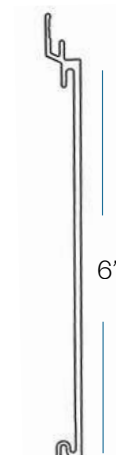
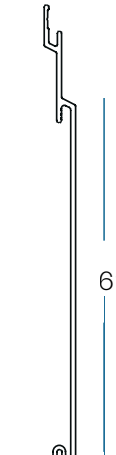
V-Groove Perforated Soffit LENGTH: 12'	V-Groove Siding & Soffit LENGTH: 24'	V-Groove Siding & Soffit LENGTH: 24'	Flush Panel LENGTH: 24'	Channel LENGTH: 24'
				

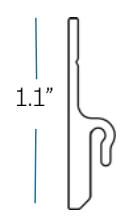
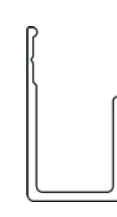
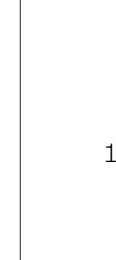
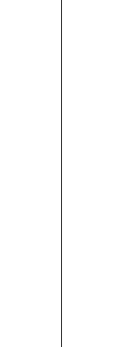
Rain Screen clip LENGTH: 12'	J-Trim LENGTH: 12'	Starter Strip LENGTH: 12'	Splicer LENGTH: 12'
			

LUXYCLAD® Siding & Soffit is offered as a comprehensive system, featuring multiple siding profiles and a variety of trim pieces to suit any architectural style. Designed for durability and ease of installation, our products provide a seamless, modern look while ensuring long-lasting performance. Whether you're aiming for a sleek contemporary finish or a more traditional aesthetic, LUXYCLAD® has the perfect solution to elevate your project.

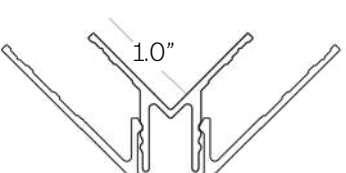
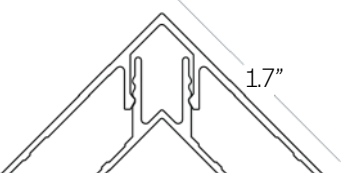
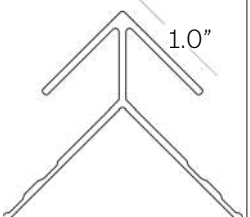
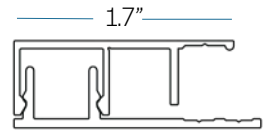
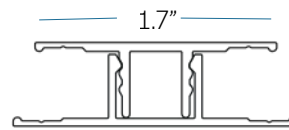
Inside Corner LENGTH: 12'	Outside Corner 2 Piece LENGTH: 12'	Outside Corner 1 Piece LENGTH: 12'	Finishing Strip LENGTH: 12'	Flat cap LENGTH: 12'
				

New 1" Precision Trims

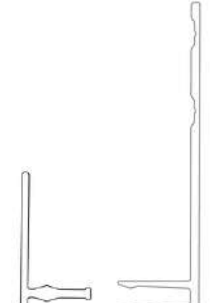
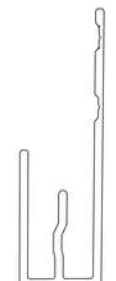
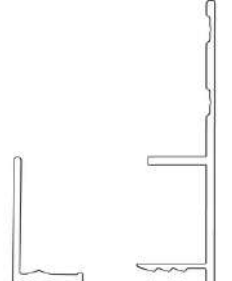
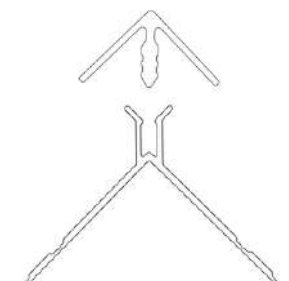
J-Trim LENGTH: 12'	J-Trim Base + Cap LENGTH: 12'	J-Trim Starter Strip LENGTH: 12'	Finishing Cap + Base LENGTH: 12'	Outside Corner + Base LENGTH: 12'
				



ADDITIONAL FEATURES & BENEFITS OF LUXYCLAD

Thermal Performance:

LUXYCLAD® systems contribute to improved building insulation and energy efficiency through their ventilated rain screen design, promoting natural airflow and reducing thermal bridging.

Versatility & Customization:

Available in a wide range of colors, finishes, and sizes, Luxyclad can be tailored to match diverse architectural styles and project specifications.

Longevity & Lifecycle Benefits:

The combination of impact resistance, UV stability, and corrosion resistance ensures a long service life, reducing replacement costs and supporting sustainable building practices.

Ease of Maintenance:

The durable finishes require minimal upkeep, maintaining their aesthetic appeal over time with simple cleaning and occasional inspections.



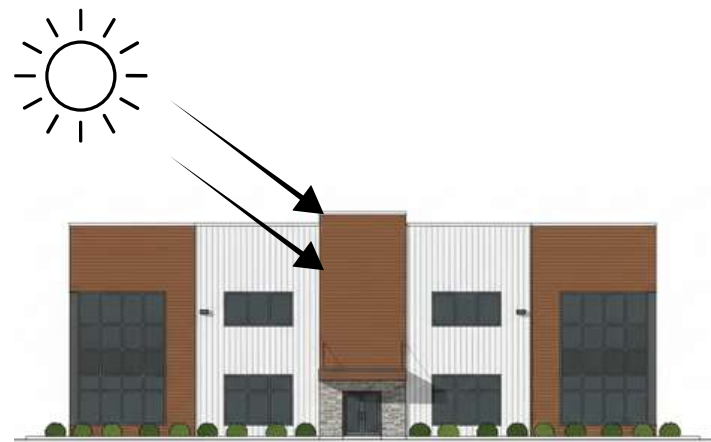

HIGH UV RESISTANCE

LUXYCLAD® high-performance finishes are AAMA 2604/05 rated, making them highly resistant to ultra violet (UV) rays which result in a long lasting, highly aesthetic product.



CORROSION RESISTANT

LUXYCLAD® is made from architectural grade aluminum, sealed to offer extremely high weatherability and corrosion resistance even in the most extreme environments.



NON COMBUSTIBLE & NON TOXIC

Class A fire rated, LUXYCLAD® is non-combustible and does not produce toxic fumes even at extremely high temperatures.



SUSTAINABLE

LUXYCLAD® is manufactured from 70% recycled content and finished with hyper durable powder coatings which contain zero volatile organic compounds (VOC's). Our products are completely recyclable at the end of their life cycle.





SUSTAINABLE COMMITMENT

At LUXYCLAD®, we are dedicated to minimizing our environmental impact. Our manufacturing process is designed to adhere to green building standards, ensuring a responsible footprint.

Sustainable Materials

Crafted from 70% recycled aluminum, LUXYCLAD® systems are fully recyclable at the end of their life cycle, reinforcing our commitment to a circular economy and sustainable construction.



LUXYCLAD® products meet or exceed industry sustainability standards and certifications. By combining design flexibility, performance, and environmental responsibility, we deliver high-quality cladding solutions that support a more sustainable built environment.

Why Choose Our Finishes

Our finishes are applied using environmentally responsible powder coating, compliant with AAMA 2604 and 2605 standards. This method provides:

- Exceptional color retention and long-term durability
- Zero VOC emissions during application
- Reduced maintenance and waste over time



FINISHES

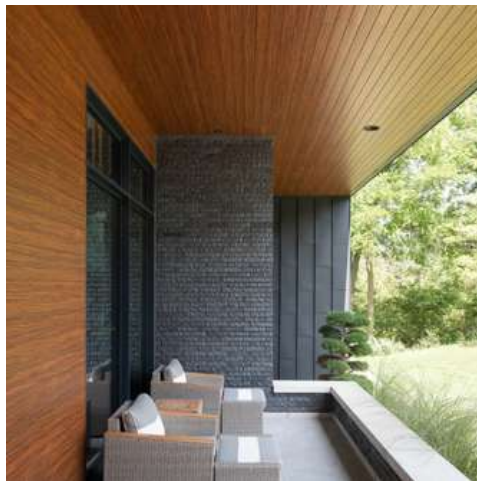

Our products are ideal for exterior, interior, and high-traffic architectural applications, offering high resistance to fire, humidity, salt, detergents, and UV exposure. These state-of-the-art finishes, combined with the material properties of extruded aluminum, result in one of the most durable and long-lasting cladding systems on the market.



LUXYCLAD® offers a wide range of aesthetically appealing and environmentally friendly wood alternative finishes. These highly durable finishes do not require the high maintenance of real wood, making them a cost-effective and sustainable choice for modern architecture. Our finishes are available in a variety of textures, colors, and patterns, allowing for versatile design options that can perfectly match your project's aesthetic.



LUXYCLAD® offers a variety of solid colors, from vibrant to subtle shades.

We provide custom color matching and metallic finishes for a unique, glamorous touch to your home's exterior.

Contact Us

76 Ridley Road
St. Catharines L2S 3Y8, ON Canada
info@luxyclad.com
1 (877)-255-1022



www.luxyclad.com

